

Chem-Free IRON REDUCTION SYSTEMS INSTALLATION AND OPERATING INSTRUCTIONS

Chem-Free Iron Filter Models

Aqua-Pure® Models:

| | |
|----------------|-----------------|
| APIF075 | APIF075M |
| APIF100 | APIF100M |
| APIF150 | APIF150M |
| APIF200 | APIF200M |
| APIF300 | APIF300M |

MacCLEAN Models:

| | |
|-----------------|------------------|
| MCIF0751 | MCIF0751M |
| MCIF1001 | MCIF1001M |
| MCIF1501 | MCIF1501M |
| MCIF2001 | MCIF2001M |
| MCIF3001 | MCIF3001M |

(Installer, please leave with homeowner.)

IN318 0107



CUNO Incorporated
400 Research Parkway
Meriden, CT 06450 U.S.A.

SAFETY INFORMATION

Read, understand, and follow all safety information contained in these instructions prior to installation and use of the CUNO MCIF & APIF Series Residential Chem-Free Iron Reduction Filter. Retain these instructions for future reference. Failure to follow installation, operation and maintenance instructions may result in property damage and will void warranty.

Intended use:

The CUNO MCIF & APIF Series Residential Chem-Free Iron Reduction Filter is intended for use in homes and has not been evaluated for other uses. This system is intended to be installed near the entry point of a home water line, and must be installed by qualified professional installers or licensed plumbing contractors according to in accordance with state and local plumbing codes and these installation instructions. Installation outside require a weather cover and the transformer must be in a dry location.

| EXPLANATION OF SIGNAL WORD CONSEQUENCES | |
|--|---|
|  WARNING | Indicates a potentially hazardous situation, which, if not avoided, could result in death or serious injury and/or property damage. |
| CAUTION | Indicates a potentially hazardous situation, which, if not avoided, may result in property damage. |

WARNING

To reduce the risk associated with ingestion of contaminants due to use with water that is microbiologically unsafe or of unknown quality:

- Do not use with water that is microbiologically unsafe or of unknown quality without adequate disinfection before or after the system.

To reduce the risk associated with a hazardous voltage due to installation on a system that requires use of the cold water system as a safety ground:

- If the home electrical system requires use of the cold water system as an electrical safety ground, a jumper must be used to ensure the ground connection across the softener piping — refer installation to qualified personnel.

To reduce the risk associated with back strain due to the heavy weight of the various system components:

- Follow safe lifting procedures.

To reduce the risk associated with hazardous voltage due to damage of the wall mounted power supply:

- Do not use the water treatment unit if the wall mounted power supply is damaged, contact qualified service personnel for repair.

CAUTION

To reduce the risk associated with property damage due to water leakage:

- Read and follow Use instructions before installation and use of this water treatment system.
- Installation must comply with existing state or local plumbing codes;
- Protect from freezing. Drain system when room temperature drops below 40°F (4.4°C);
- Do not install on systems where line pressures above 100 psi (689 kPa) may occur;
- The system should be installed on cold water lines only;
- Do not install system where water lines could be subjected to vacuum conditions without appropriate measures for vacuum prevention.
- Pay particular attention to correct orientation of control valve. Water flow should match arrow on control valve;
- When water supply is shut off, shut off fuel or electric power to water heater;
- Do not use torches or other heat sources near plastic plumbing;
- Take care when using pliers or pipe wrenches to tighten plastic fittings; overtightening may damage fittings resulting in leakage;
- On plastic fittings, use thread sealing tape only. Never use pipe sealant or pipe dope on plastic fittings.
- Overtightening could cause the nut to fail unexpectedly and cause water damage to the dwelling.

IMPORTANT NOTES

- The system should be installed on cold water lines only.
- SHUT OFF FUEL SUPPLY TO WATER HEATER after water is shut off.
- Failure to follow instructions may void warranty.
- The INLET and OUTLET of other water treatment equipment will vary depending on the the control valve brand used. Please verify the INLET and OUTLET openings on each control valve before making the plumbing connections.
- Do not apply heat near Hydro-Charger, as damage may occur. On badly scaled, older plumbing systems, it may be advantageous to install a **WYE STRAINER** to help prevent plugging of the Hydro-Charger nozzle with scale or debris. **The use of a WYE STRAINER must precede the hydrocharger on the inlet side by a MINIMUM OF 10”.**
- If existing water system includes a captive-air type pressure tank (bladder) and it is desirable to install an additional air to water type with an air release (not as a split steam type installation) install an air to water type pressure tank between the Hydro-Charger and the existing captive air type pressure tank.
- Before proceeding with Hydro-Charger installed, re-verify adequate pumping rate pumping by following the procedure described in SECTION 2. After verification of adequate flow, depressurize system as described previously.
- If installation is to be split streamed prior to filter vessel or is it a public water supply (see figure 1), or refer to special instructions on page 3-13.
- When the duration of the suction is too long, the cold water may have a milky appearance caused by excess air in the water system. Correct this condition by reducing the duration of suction. This condition is commonly associated with bladder type pressure tanks. In extreme cases where elimination of excess air prevents system from performing satisfactorily, it may be necessary to install an air to water pressure tank with an air release valve.
- Due to the nature of the Chem-Free Iron Reduction media, on start up it sometimes requires 2 or 3 days for the Chem-Free Iron Filter to reduce Iron and Manganese below staining levels. Do not be alarmed if this occurs. During the initial start up and subsequent first couple automatic regeneration cycles, a small amount of fine white and beige media may be observed in the drain water and or drain area. This is normal and beneficial for the efficient operation of your Chem-Free Iron Filter Reduction System.
- Failure to set PRESSURE SWITCH as described above will NOT allow proper closing of SOLENOID VALVE during periods of low system pressure. Improper function of SOLENOID VALVE will cause total failure of system.
- The Backwashing Frequency Schedules are based on average water consumption rates and are merely guides. They are NOT intended to be used if water is used by outside spigots, a swimming pool, geothermal heat pump, or other high water usage devices or activities. If your application includes any of these, and you have already determined your model Chem-Free System is capable of handling the flow rates involved, refer to the next paragraph for instructions on setting Backwash Frequency.
- Replenishment of pH adjusting component of media may be required periodically, the frequency of which is dependent on raw water pH, manganese concentration and water consumption rate. Consult dealer for more information.
- For satisfactory performance, indicated durations should not be exceeded. Flow rates specified are adequate for normal residential applications. Do not use Service or Peak flow rates when sizing commercial applications or if treated water is to supply a geothermal heat pump, swimming pool, etc. (contact dealer before selecting equipment). Service flow rates have been tested against NSF Standard 42 and have a rated pressure drop of less than 10 psi.
- For system to operate properly, pumping rate of well pump MUST be sufficient to backwash unit at rate specified.
- Service Pipe size is 3/4” on models not shown above: MCIF0750, 0750M, 1000, 1000M, 1500, 1500M, 2000, 2000M, 3000 and 3000M.

TABLE OF CONTENTS

| <u>SECTION</u> | <u>DESCRIPTION</u> |
|----------------|----------------------------------|
| 1 | GENERAL INFORMATION |
| 2 | BEFORE INSTALLATION |
| 3 | INSTALLATION |
| 4 | PLUMBING SYSTEM CLEAN-UP |
| 5 | BACKWASHING INSTRUCTIONS |
| 6 | TROUBLESHOOTING |
| 7 | SPECIFICATION AND OPERATING DATA |

SECTION 1: GENERAL INFORMATION

Congratulations on your purchase of a Chem-Free Iron Reduction System! The Chem-Free System reduces dissolved, precipitated and bacterial iron from your water supply. Contrary to conventional methods, your Chem-Free System requires NO chemicals (either added to the water supply or the filter). This unique process requires ONLY periodic backwashing for a few minutes to flush out entrapped iron that has accumulated in the filter tank.

When properly installed, the Chem-Free Iron Reduction System will provide many years of virtually trouble-free service. Read this manual all the way through first, and then follow the instruction steps in the proper sequence.

The Chem-Free Iron Reduction System is intended to be used on residential water systems which use a standard submersible well pump, one that utilizes a pressure tank and a pressure switch to stop and start the well pump. If you have a jet pump or a constant pressure pump you will need to utilize another product type to address your iron, manganese and hydrogen sulfide problems. Please contact our technical department should you have any questions at 1-866-693-2543 and select option 1.

Description and Operation of the System:

The Chem-Free Filter System consists of two major components which are:

- 1) HYDRO-CHARGER located between the well head and the pressure tank, which adds a small amount of air to the iron-laden water whenever the well pump runs.
- 2) A backwashing type filter containing a special media that causes the iron in the "Hydro-Charged" water to precipitate throughout the filter bed (rather than on the surface as in chemical oxidizing filters). This process produces an iron reduction capacity of 30,000 to 50,000 parts per million (ppm) compared to 6,000 to 8,000 ppm for chemical oxidation processes. The media DOES NOT require a chemical regenerant (such as potassium permanganate) for oxygen enrichment, salt, chlorine or any other chemicals.

Your Chem-Free Filter System automatically adjusts the pH to neutral or higher on acid water WITHOUT an acid neutralizer (a required piece of equipment with chemical oxidation filters whenever the pH is less than 6.7). The ability to raise pH when it is below neutral (7 or less) greatly enhances the Chem-Free System's ability to reduce iron efficiently.

IMPORTANT NOTE

Replenishment of the component of the filter media that adjusts pH, MpH Adder, may be required periodically, the frequency of which is dependent on the raw water pH, the manganese (Mn) concentration in the water (if any) and the water consumption rate.

Periodic backwashing of the filter bed flushes the precipitated iron to the drain and readies the filter for use again. The duration of the backwash procedure will vary depending on several factors, but generally totals just 10 minutes (factory setting). The frequency of backwashing depends on iron concentration and water usage, and ranges from daily to once every 99 days. The volume of water consumed during the entire backwashing procedure is approximately 50 gallons at the factory backwash settings (one (1) cubic foot models).

SECTION 2: BEFORE INSTALLATION

Inspecting And Handling Your Filter:

Inspect the equipment for shipping damage. If damaged, notify the transportation company and request a damage inspection. Handle the filter with care. Damage can occur if dropped or set on sharp, uneven projections on the floor. Do not turn the filter upside down. Installation must comply with state and local laws and regulations.

Make Sure Your Water Has Been Thoroughly Tested:

An analysis of your water should be made prior to the selection of your water conditioning equipment. Your Chem-Free System dealer will generally perform this service for you, and may send a sample to the factory for analysis and recommendations. Enter your analysis below for a permanent record.

Note: Hydrogen sulfide (H₂S) must be tested for at the well site. For accuracy, the sample must be drawn with the pump RUNNING, and the test be completed within ONE minute after the sample is drawn.

Analysis of Your Water

| | | |
|-------------------------------------|-------|-----|
| Iron (Fe) | _____ | ppm |
| Manganese (Mn) | _____ | ppm |
| pH | _____ | ppm |
| Tannins (Humic Acid) | _____ | ppm |
| Hydrogen Sulfide (H ₂ S) | _____ | ppm |
| Hardness | _____ | ppm |
| Other _____ | _____ | |
| Other _____ | _____ | |

Iron (Fe)

Iron concentrations as low as 0.3 ppm (0.1 ppm under some conditions) will cause staining. The iron concentration, together with the flow rate demand and the consumption rate of the water determines the size of the filter system required. The higher these factors are, the larger the required system. The Chem-Free Iron Reduction Systems is capable of reducing the three main types of iron found in water supplies: Soluble Iron (also known as clear water iron); Precipitated Iron (also known as red iron); and Bacteria Iron also known as “clear water” or ferrous iron), precipitated iron (also known as red water iron) and Bacteria Iron. There is an upper limit of 15 ppm iron concentration for the Chem-Free System; special care must be taken when selecting a filter model if your water has a combination of high iron, very low pH and/or manganese levels above 0.2 ppm.

The Chem-Free System is not bactericidal, i.e. it does not remove or kill “bacterial iron”. It reduces the iron upon which the bacteria may live or which it deposits in your plumbing fixtures, thus helping to eliminate its effects.

Manganese (Mn)

The presence of manganese can be bothersome, even for a Chem-Free Iron Reduction System (and is devastating for chemical oxidizing systems). As little as 0.05 ppm of manganese can produce a brownish or black stain. The ability of the Chem-Free System to reduce manganese depends on its concentration and the pH of the water.

Although not specifically designed for the reduction of manganese, the oxidation of manganese is very similar to that of iron, therefore, a pH of 8.2 or higher must be obtained. When this pH level is achieved, the precipitation of manganese may more readily occur. To accomplish this, models are available where the media contains additional quantities of MpH Adder, the pH raising component (model designations with “M” suffix). In any application involving manganese, a larger model filter is generally recommended (but only if the pumping rate is sufficient to backwash the larger size).

If, however, the manganese concentration is low (0.1 ppm or less) and the pH is 6.5 or higher, a Chem-Free System containing standard Chem-Free System media will generally perform satisfactorily, although backwashing should be performed at more frequent intervals. Under more severe conditions where the pH is very low and/or the manganese concentration is high, an acid neutralizer installed ahead of the Chem-Free System will maintain the required 8.2 pH level longer than the Chem-Free media will between replenishment with MpH Adder.

pH

The pH of water measures its acidity. Water with a pH of less than 7.0 is acidic, above 7.0 it is alkaline, and a pH of 7.0 is neutral. The lower the pH value, the greater the acidity, and the higher the pH value, the more alkaline. Acidic water (pH less than 7.0) is corrosive to pipes, appliances, etc. A pH of 7.0 or higher facilitates iron reduction, which is why the Chem-Free System is designed to increase the pH when it is less than 7.0.

The pH increasing component of Chem-Free media is “sacrificial”, that is, it slowly dissolves during the process of increasing pH. The rate at which this occurs is proportional to the degree of the pH increase and the water consumption rate (i.e., the greater the pH increase and water consumption, the greater the sacrificial rate). Thus, when the pH is increased to 8.2 or more, as is necessary when manganese is present, the sacrificial rate is even greater. Under the most severe conditions, the MpH Adder component of the media may have to be replenished two to four times per year. On the other hand, if the raw water pH is 7.0 or above and no manganese is present, the sacrificial rate is very slight (see NOTE, Section 1).

Tannins (Humic Acid)

Tannins (a humic acid), which may be present in some water supplies, are the result of various forms of decaying vegetation (the test for tannins can be performed by your dealer). Tannins can cause problems in the operation of the Chem-Free System by forming a sticky coating on the media, thus rendering it incapable of filtering the iron. Generally with tannin concentrations of **0.5 ppm or less**, more frequent backwashing will help prevent the sticky coating from forming. It does appear, however, that the level of tannin concentration affects the operation of the Chem-Free filter differently in different geographical areas (in some areas, the Chem-Free System will perform satisfactorily when tannin concentration is considerably greater than 0.5 ppm). It is therefore recommended that if the tannin concentration is **0.5 ppm or more**, contact your dealer BEFORE installing the system.

Hydrogen Sulfide (H₂S)

Hydrogen sulfide (often referred to as “sulfur”), is easily detected by its objectionable “rotten egg” odor. Sulfur corrodes iron, brass, copper and silver. While the Chem-Free System is not intended to be used as a sulfur filter, it has the capability of reducing sulfur in concentrations of up to 2 or 3 ppm, and sometimes as high as 5 ppm. Whenever hydrogen sulfide is present, backwashing must be performed at more frequent intervals, and the pumping system **MUST** include a standard air-to-water pressure tank with an air-relief valve. The air to water pressure tank must be installed between the Hydro-Charger and existing pressure tank.

Check Your Water Pressure and Pumping Rate:

Two water system conditions must be checked carefully to avoid unsatisfactory operation or equipment damage:

- 1) **MINIMUM** water pressure required at the filter tank inlet is 20 psi. **If pressure is over 100 psi, a pressure reducing valve must be installed in the water supply line ahead of the Hydro-Charger. NOTE: If you have a municipal or community water supply and daytime water pressure is 80 psi or more, nighttime pressure may exceed 100 psi. Call your local water department or plant operator to obtain pressure readings. If you have a private well, the gauge on the pressure tank will indicate the high and low system pressure. Record your water pressure date below:**

Water Pressure

Low _____ PSI High _____ PSI

CAUTION

Damage to system can occur (including possible mineral tank failure) if system is subjected to a vacuum. The installer should take appropriate measures if there is the possibility a vacuum may occur. This would include the installation of an appropriate device in the supply line to the system, i.e. a vacuum breaker or backflow prevention device. Vacuum damage may cause property damage and voids the factory warranty.

- 2) The pumping rate of your well pump must be sufficient for satisfactory operation of the Hydro-Charger and to backwash the filter. **For models MCIF1001 and APIF100, the required rate is 5 gpm (refer to Specifications and Operating Data for the backwash requirements for other models). To measure the pumping rate of your pump, follow these instructions:**

- a. Make certain no water is being drawn. Open spigot nearest pressure tank. When pump starts, close spigot and measure time (in seconds) to refill pressure tank (when pump shuts off). This figure represents Cycle Time.
- b. With the pressure tank full, draw water into a container of known volume, measure the number of gallons drawn until the pump starts again. This is the Draw-Down. Divide this figure by Cycle Time and multiply the result by 60 to arrive at the Pumping Rate in gallons per minute (gpm). To aid in your calculation, insert the data in the following formula:

$$\text{Draw-Down} \text{ _____ (gallons)} \div \text{Cycle Time} \text{ _____ (seconds)} \times 60 = \text{Pumping Rate} \text{ _____ (gpm)}$$

Example: Cycle Time is 63 seconds; Draw-Down is 8 gallons, then Pumping Rate equals:

$$8 \text{ gallons} \div 63 \text{ seconds} \times 60 = 7.8 \text{ gpm}$$

NOTE: The addition of the Hydro-Charger to the pumping system or plumbing and other water treatment devices (such as an acid neutralizer) may reduce the flow rate at the drain to an inadequate level to properly backwash the system. If you are uncertain whether your flow rate is adequate, contact your dealer **BEFORE** installing your Chem-Free System so that corrective action, if required, may be taken.

CAUTION

Locate Water Conditioning Equipment Correctly: Failure to do so may result in property damage and will void warranty.

Select the location of your filter unit with care. Various conditions which contribute to proper location are as follows:

- 1) Locate as close as possible to water supply source.
- 2) Locate as close as possible to a floor or laundry tub drain.
- 3) Locate in correct relationship to other water conditioning equipment (See Figures 1, 3 or 7 in Sec. 3)
- 4) Filters and softeners should be located in the supply line BEFORE the water heater. Temperatures above 100°F (38°C) damage filters and softeners and will void the factory warranty.
- 5) Do NOT install a filter or softener in a location where freezing temperatures may occur. Freezing may cause permanent damage to this type of equipment and will also void the factory warranty.
- 6) Allow sufficient space around the unit for easy servicing.
- 7) If your water source is a community water supply, a public water supply, or you wish to bypass water used for a geothermal heat pump, lawn sprinkling, out-buildings or other high demand applications, refer to Figures 3 or 7 for additional equipment required. Also refer to the Special Instructions on page 3-13.

The Importance of Your Pressure Tank:

The pressure tank found on private well systems becomes an integral part of the Chem-Free Iron Reduction System by providing necessary mixing and “residence time” to the “Hydro-Charged” water. While the Chem-Free Iron Reduction System will perform satisfactorily with either a captive-air (bladder) type pressure tank or a standard air-to-water type with an air volume control (air-relief valve), the bladder type requires more careful adjustment of the Hydro-Charger to prevent gasses from collecting in the pressure tank and the head area of the filter tank.

IMPORTANT: A properly sized pressure tank of either style will require a minimum pump cycle of 60 seconds to refill from the well pump on-to-off pressure settings.

Under more severe operating conditions (low pH, high iron, manganese, and small concentrations of sulfur), a standard air-to-water type pressure tank with an air-relief valve **MUST** be used (if a bladder type tank is already in place, do not remove it, install the air-to-water pressure tank between the Hydro-Charger and the bladder type tank).

IMPORTANT NOTE

If your pressure tank (or any part of your water system) is not functioning properly, corrective action MUST be taken before installation of your Chem-Free Iron Reduction System.

CAUTION

Improper installation and use may result in property damage due to water leakage.

Facts To Remember While Planning Your Installation:

- 1) All installation procedures **MUST** conform to local and state plumbing codes.
- 2) All water **MUST** pass through the Hydro-Charger Assembly, pressure tank and the Chem-Free Filter System, or refer to the special instructions for a split-stream installation in Section 3. (System may malfunction resulting in property damage if this instruction is ignored and warranty will be voided.)
- 3) If lawn sprinkling, a swimming pool, geothermal heating/cooling or water for other devices/activities are to be treated by the Chem-Free Reduction System, a larger model filter **MUST** be selected to accommodate the higher flow rate demands of these items. The pumping rate of the well pump must be sufficient to accommodate these items plus the backwashing requirement of the filter. Consult your dealer for alternative instructions if the pumping rate is insufficient.
- 4) Remember that the filter **INLET** is attached to the pipe that supplies water (i.e. runs to the pump), and the **OUTLET** is the line that runs toward the hot water heater.
- 5) Before commencing the installation, it is advisable to study the existing piping system and to determine the size, number and type of fittings required. Typical system schematics shown in these instructions (Figures 1) will be of assistance.
NOTE: If the plumbing system is used as the ground leg of the electric supply, continuity should be maintained by installing ground straps around any non-conductive plastic piping used in installation.
- 6) **IMPORTANT:** Always use thread tape on threaded plastic fittings.

CAUTION

On plastic fittings, use thread sealing tape only. Never use pipe sealant or pipe dope on plastic fittings.

SECTION 3: IMPORTANT INSTALLATION INSTRUCTIONS

Proper installation sequence of water conditioning equipment is very important. Refer to the following diagram for your particular water supply. Failure to follow installation, operation, and maintenance instructions may result in property damage due to leakage and will void warranty.

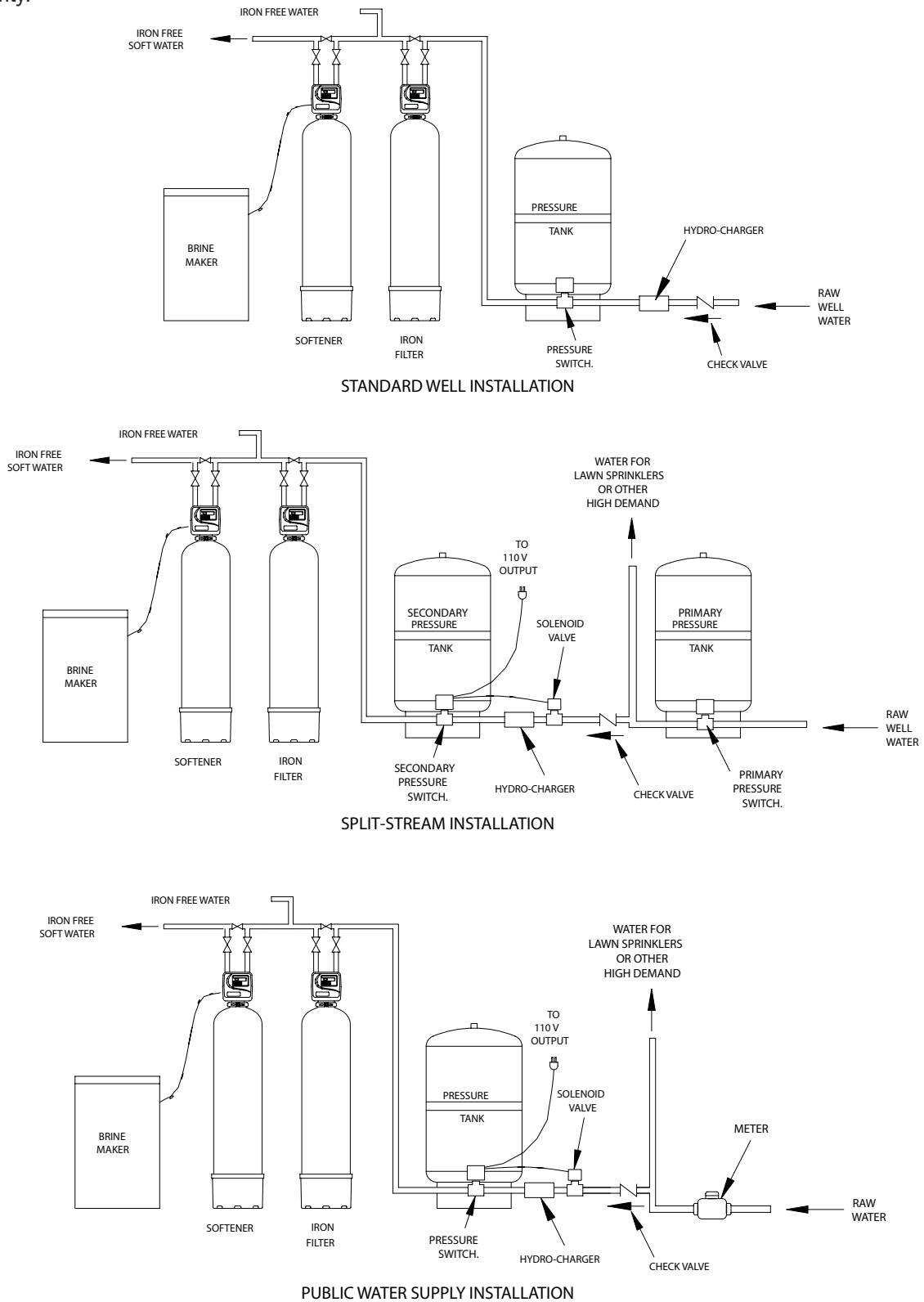

Figure 1

IMPORTANT

The **Inlet** and **Outlet** of other water treatment equipment product will vary depending on the control valve brand used. Please verify the **INLET** and **OUTLET** openings on each control valve before making the plumbing connections.

NOTE: Have you read “ **Section 4**”, **PLUMBING SYSTEM CLEANUP**, for instructions on some procedures that may need to be performed first?

| GRAVEL AND CHEM-FREE MEDIA SCHEDULE | | | | | |
|--|---------------------|---------------------|---------------------|---------------------|---------------------|
| Unit Model Number | APIF075 MCIF0751 | APIF100 MCIF1001 | APIF150 MCIF1501 | APIF200 MCIF2001 | APIF300 MCIF3001 |
| Chem-Free Filter Media | MC-075P | MC-10P | MC-10P MC-050P | MC-10P (2) | MC-10P (3) |

NOTE: If you ordered an “M” model Chem-Free Free Iron Filter, Iron Reduction System the filter pack media would be designated by an M at the end of the part number i.e. MC-10MP.

To load the filter media into the filter tank please use the follow steps. This is necessary to ensure that the distributor tube has not been pulled up when the control valve was removed from the top of the filter tank.

Step 1

- a) Remove from the shipping carton the filter unit
- b) Carefully remove the control valve from the filter vessel by releasing the latch on the clamping collar (see figure 7 on 3-13).
- c) Set all items aside for future use. Ensure that the following items have been shipped entirely with the unit to allow for proper and complete installation. If any item is missing or has been damaged in transit contact our technical department for help and replacement at 866-693-2543 (option 1) from 7:30 am to 4:30pm EST. Please be prepared to supply the model and serial number when you call should you need help.
 - i. Control valve
 - ii. Mineral tank (also a reducing bushing and flanged adapter on MCIF3001 and APIF300)
 - iii. Bypass valve
 - iv. 1” Male NPT Connection Kit
 - v. Chem-Free Media (amount will vary by filter size)
 - vi. Distributor Tube
 - vii. Drain line assembly kit
 - viii. Parts bag
 - ix. Valve wrench
 - x. Installation and Operating Instruction
 - xi. Loading funnel
 - xii. Tube extension device and cap
- d) Remove the distributor tube in the filter vessel, set aside and pour the gravel into a clean pail for later use.
- e) Reinsert the distributor tube into the filter vessel and ensure the tube is centered in the tank; a dimple is in the center of the filter vessel to help in doing so. Using the tube extension device and cap, cover the distributor tube opening to prevent filter media and gravel from entering the distributor tube during the loading of the filter vessel.
- f) Place the funnel provided, in the opening of the mineral tank to aid in loading the gravel and filter media. Pour the QC gravel into the filter vessel slowly. While holding the distributor tube in place, shake the filter vessel from side to side gently, to aid in leveling the QC gravel. Do not allow gravel to get under the basket of the distributor tube during the loading of gravel. If this happens, pour out the gravel and remove the distributor tube once again. Next locate the filter media and slowly pour into the filter vessel. Again shake the filter vessel from side to side to aid in leveling the media. Next, using a hose or clean pail, fill the filter vessel with water to saturate the filter media and expel any air that may be present, remove the extension tube, cap and funnel, and save for future servicing.
- g) Using a clean dry rag, wipe the opening of the mineral tank to remove any dust or residue from the opening to receive the control valve. Apply silicone lubricant to the filter vessel flanged opening and control valve O-rings that seal against the filter vessel and pilot tube O-ring in the center of the control valve. Place the center of the control valve over the distributor tube and push down on the control valve until it contacts the flange on the filter vessel. Using one swift and even push downward, seat the control valve into the opening of the filter vessel. Do not use a rocking motion to seat the control valve as this could roll or pinch the O-ring, causing a leak between the control valve and filter vessel. Place the clamp assembly around the flange of the filter vessel and the control valve, paying particular attention to the proper orientation of the clamp. To secure the clamp in place install the latch. Refer to Figure 7 on 3-13 to determine the proper orientation for the clamp. The latch needs to be installed with the smaller opening toward the clamp. Attach the bypass to the control valve as shown in Figure 7 on page 3-13.

Step 2

Shut off water at main supply. On a PRIVATE WELL SYSTEM turn off the power to the WELL PUMP and drain PRESSURE TANK. Make certain all water pressure has been relieved from complete water system by opening nearest faucet to drain water system. SHUT OFF FUEL SUPPLY TO WATER HEATER OR BOILER.

Step 3

Cut main supply line as required to fit Hydro-Charger in plumbing between well pump and pressure tank (Hydro-Charger may be installed in a vertical or horizontal position). The Hydro-Charger has been supplied with both 1" threaded and 1" barbed (insert) fittings to allow for installation with various types of piping materials. When using the threaded nipples, use thread tape only. When using barbed (insert) fittings, appropriate pipe clamps must be used. Once installed the quick release nipples allow the Hydro-Charger to be rotated, so the air draw adjustment screw is accessible for adjustment by a small bladed screwdriver. Allow at least 10 inches of straight run of 1" pipe on both INLET and OUTLET side of the Hydro-Charger. Refer to Figure 2 for correct assembly. The quick release nipples also acts as a union to facilitate the Hydro-Charger removal, inspection and cleaning as needed. With an installation on PVC pipe and copper tubing it may require the addition of a normal plumbing union to aid in removal from the plumbing due to the rigidity of that type of material. Make certain the directional arrows on the Hydro-Charger points toward the pressure tank and the pressure control switch is located on the pressure tank side of Hydro-Charger as in Figure 1. Rapid cycling of pump may occur if the pressure control switch is located on well side. If a check valve is located between hydrocharger and pressure tank, it may prevent the Hydro-Charger from performing properly. Relocate to well side of Hydro-Charger.

Step 4

Turn back on the power to the well pump and pressurize the water lines to allow for adjustment of the Hydro-Charger. Check for leaks and adjust as necessary.

IMPORTANT NOTES

- Do not apply heat near Hydro-Charger, as damage may occur. On badly scaled, older plumbing systems, it may be advantageous to install a **WYE STRAINER** to help prevent plugging of the Hydro-Charger nozzle with scale or debris. **The use of a WYE STRAINER must precede the hydrocharger on the inlet side by a MINIMUM OF 10"**.
- If existing water system includes a captive-air type pressure tank (bladder) and it is desirable to install an additional air to water type with an air release (not as a split steam type installation) install an air to water type pressure tank between the Hydro-Charger and the existing captive air type pressure tank.
- **Before proceeding with Hydro-Charger installed, re-verify adequate pumping rate pumping by following the procedure described in SECTION 2. After verification of adequate flow, depressurize system as described previously.**
- **If installation is to be split streamed prior to filter vessel or is it a public water supply (see figure 1), or refer to special instructions on page 3-13.**

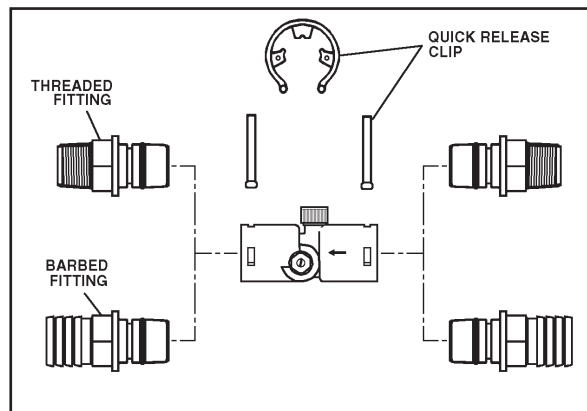

Figure 2: HYDRO-CHARGER INSTALLATION

Step 5

Set Hydro-Charger by following the following steps:

- a) Open nearest faucet until well pump starts, then close faucet.
- b) Place a finger lightly over the SUCTION PORT (Figure 4). A slight suction should be detected for approximately ONE THIRD (1/3) of pumping cycle time. (Do not confuse with ONE THIRD (1/3) of pressure range).
- c) If suction is too short, increase by turning air adjustment screw (Figure 4), CLOCKWISE. To decrease duration, turn COUNTERCLOCK WISE.
- d) Repeat steps (a) through (c) until proper setting is obtained. The optimum cycle time is 60 seconds or more, with an air draw of 20 seconds minimum. Position DRAIN LINE over drain and secure firmly. To prevent back-siphoning of sewer water, provide an air gap of at least 2 inches or 2 pipe diameters between end of drain hose and drain (Figure 6). Do not raise DRAIN LINE more than 10 ft. above floor.

IMPORTANT NOTES

When the duration of the suction is too long, the cold water may have a milky appearance caused by excess air in the water system. Correct this condition by reducing the duration of suction. This condition is commonly associated with bladder type pressure tanks. In extreme cases where elimination of excess air prevents system from performing satisfactorily, it may be necessary to install an air to water pressure tank with an air release valve.

Step 6

Turn off the electrical source to the water well pump or the close the water shut off valve on a municipal water supply to the dwelling once again. Depressurize the water system by opening the nearest faucet to drain water from the water system in order to allow the installation of the Chem-Free Iron Reduction System.

Step 7

Determine location and cut the water line on the supply side of the pressure tank as required to fit the plumbing to the control valve connection fittings. You may want to install a separate three valve bypass prior to the control valve in case the supplied bypass valve requires maintenance in order to provide undisturbed water use.

Step 8

Assemble and attach bypass valve to the control valve. See Figure 3 if needed. Next locate and assemble the 1" NPT connection fittings before attaching them to the bypass valve. Use the appropriate method of connection to ensure a permanent connection. Please refer to figure 5 to correctly assemble the connection fittings. Install the fitting into the bypass valve, attach the plumbing to the 1" NPT male connection fittings, hand tighten the fittings nuts only. Make certain the water enters inlet and discharges through the outlet side of the bypass valve. Arrows can be viewed on the bypass valve to confirm the correct flow path. At this time make certain the bypass valve is in the bypass position and leave in that position until instructed to place in the service position. Refer to Figure 3 for proper operation.

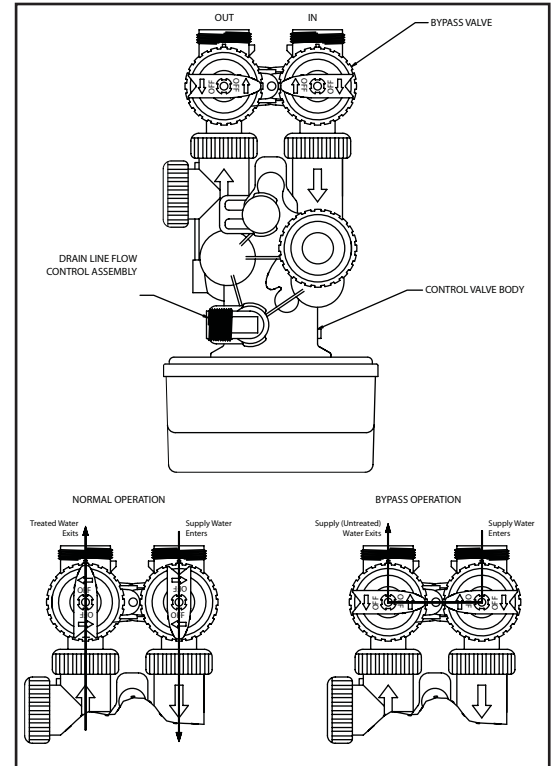

Figure 3

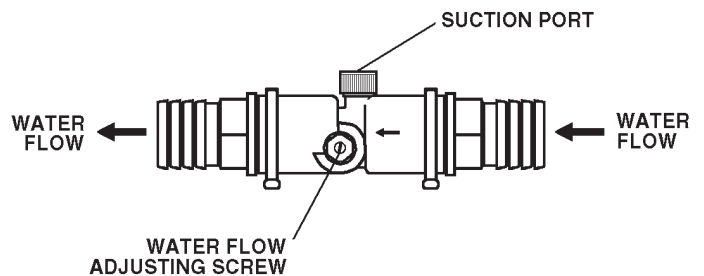

Figure 4

CAUTION

- Do not use torches or other heat sources near plastic fittings.
- Take care when using pliers or pipe wrenches to tighten plastic fittings.

Step 9

Fitting Installation Instructions

- 1) The installation fittings are designed to accommodate minor plumbing line and fittings.
- 2) Thread tape is the only type of thread sealant allowed to be used; the use of paste of any kind will void the factory warranty. Do not let the connection fittings support the plumbing, properly support the plumbing as required.
- 3) Slide the nut on first (closed and against the threads), then slip ring onto the fitting, ensuring it set correctly in groove, then the O-ring last. Use Silicone lubricant to allow for easier insertion of parts into one another.
- 4) Hand tighten the nut only, the use of pliers or wrenches of any type will void the factory warranty and may cause an unexpected failure and water will leak in your home or facility.

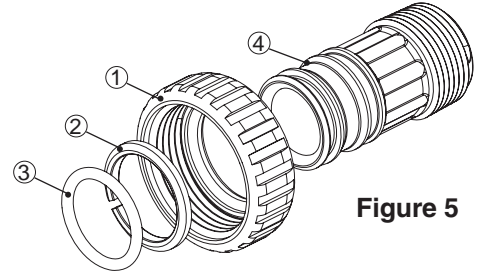

Figure 5

Use customer supplied fittings to adapt the drain line to the control valve. Support of the drain line is required to prevent damage to the drain line elbow which could lead to a water leak in the dwelling. Suitable drain line material can be Copper, PVC or CPVC pipe or PE tubing can be used to adapt to the $\frac{3}{4}$ NPT threads on the drain elbow for long or high drain lines. Use only thread sealing tape to seal the threads, hand tighten the threaded joint. To utilize polyethylene tubing as a drain line, remove the supplied nut and find the insert that was shipped in the parts kit box. Slide the nut over the polyethylene tubing and insert the sleeve into the tubing. Slide the end of the tubing into the elbow, using your hand thread the nut onto the elbow and hand tighten only. No thread tape is required to seal the threads with compression fittings.

CAUTION

Overtightening could cause the nut to fail unexpectedly and cause water damage to the dwelling.

Typical examples of proper drain line diameters and lengths are:

- 1/2" ID up to 15 feet when discharge is lower than the inlet.
- 5/8" ID up to 15 feet when discharging is slightly higher than the inlet.
- 3/4" ID when drain is 25 feet away and not higher than 4 feet above control valve.

Avoid installing drain line overhead or using flexible vinyl tubing, either may result in the filter not operating properly in reducing iron, manganese or turbidity. Some areas prohibit the use of flexible drain lines. Check with the local code officials prior to installation to ensure you conform to local, state and national plumbing codes.

Step 10

Position the DRAIN LINE over the waste drain pipe and secure firmly. To prevent back siphoning of sewer water or grey water, provide an air gap of at least two inches or 2 times the pipe diameters between the end of drain line tubing and waste drain (Figure 6). Do not raise the DRAIN LINE more than 10 feet above the floor. Check with local code officials to ensure you conform to local, state and national plumbing codes.

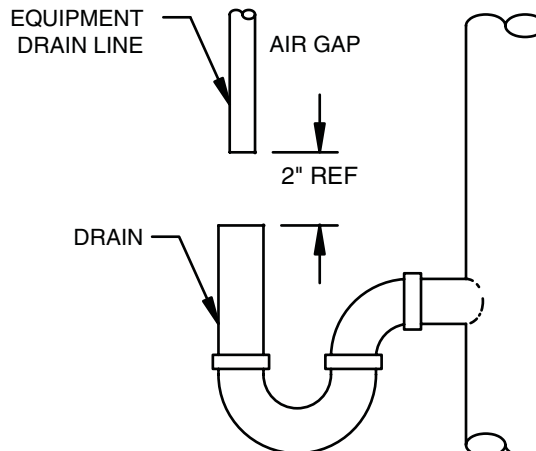

Figure 6: DRAIN

Step 11

Plug the control valve into a properly grounded 110/120V 60 Hz non switched electrical outlet. Check with your local code enforcement office to determine if it meets local codes.

Step 12

Turn back on the power source to well pump and slowly open the shut off valve to pressurize the water system. If on a public or community water supply open the main shut off valve to the dwelling.

Step 13

Set the time of day by referring to **Section 3 INSTALLATION “How to set the Time of Day”**.

Step 14

Open the valve on the water supply as required to pressurize the water lines to the dwelling or fuel source. The power to the water heater or boiler needs to be established once water has been allowed to flow back into the device, if it was drained at any time during the installation. Turn back on the power or fuel source to either the water heater or boiler if it was drained at any time during the installation. Check for leaks on all connections before leaving the job site, correct as required.

Step 15

Manually initiate regeneration of the Iron Filter by referring to the **“How To Manually Initiate Regeneration”** section of Control Valve settings in Section 3

Step 16

Once the valve is in the backwash position (C1 appears on the display) slowly open the inlet side of the bypass valve to allow water to flow into the filter vessel. Water should start to flow into the drain. Allow for any air that might have been trapped to leave the filter and go to drain. This will be detected by changes in noise in the drain line or is visible in the semi-transparent tubing. Once the air is entirely gone slowly increase the water flow to drain by opening the inlet side of the bypass valve until fully open. Refer to **Figure 3** for correct positioning. At the end of C1 position the water should be clear. If not, allow the valve to complete the manual regeneration process and initiate once again. It is very important to allow the unit to purge all fines to the waste drain from the media in the filter vessel prior to using the water. Once the flushing process has been completed you now can open the outlet side of the bypass valve to allow for filtered water to flow into the dwelling.

IMPORTANT NOTES

Due to the nature of the Chem-Free Iron Reduction media, on start up it sometimes requires 2 or 3 days for the Chem-Free Iron Filter to reduce Iron and Manganese below staining levels. Do not be alarmed if this occurs. During the initial start up and subsequent first couple automatic regeneration cycles, a small amount of fine white and beige media may be observed in the drain water and or drain area. This is normal and beneficial for the efficient operation of your Chem-Free Iron Filter Reduction System.

Step 17

The frequency of backwash is factory preset at every 4 days. If the Iron content is greater than 5 ppm, is red water or bacterial iron the unit should be washed more frequently. See tables to determine the frequency. Also if the water has tannin-lignin or hydrogen sulfide present, the filter should backwash every day. Refer to Section 5 for backwashing instructions and frequency.

BACKWASH FREQUENCY SCHEDULE

| Models MCIF 0751, 0751M APIF 0751, 0751M | | | | | | | | |
|---|----------------------|----|----|----|----|----|----|----|
| Persons in Family | IRON CONTENT - (PPM) | | | | | | | |
| | 2 | 4 | 6 | 8 | 10 | 12 | 14 | 16 |
| 1 | 12 | 12 | 12 | 12 | 12 | 12 | 12 | 12 |
| 2 | 12 | 12 | 12 | 6 | 6 | 6 | 6 | 4 |
| 3 | 12 | 12 | 6 | 6 | 6 | 4 | 4 | 3 |
| 4 | 12 | 6 | 6 | 4 | 4 | 3 | 3 | 2 |
| 5 | 12 | 6 | 6 | 4 | 3 | 3 | 2 | 2 |
| 6 | 12 | 6 | 4 | 3 | 3 | 2 | 2 | 1 |

| Models MCIF 1001, 1001M APIF 100, 100M | | | | | | | | |
|---|----------------------|----|----|----|----|----|----|----|
| Persons in Family | IRON CONTENT - (PPM) | | | | | | | |
| | 2 | 4 | 6 | 8 | 10 | 12 | 14 | 16 |
| 1 | 12 | 12 | 12 | 12 | 12 | 12 | 12 | 12 |
| 2 | 12 | 12 | 12 | 6 | 6 | 6 | 6 | 6 |
| 3 | 12 | 12 | 6 | 6 | 6 | 4 | 4 | 4 |
| 4 | 12 | 12 | 6 | 6 | 4 | 4 | 4 | 3 |
| 5 | 12 | 12 | 6 | 6 | 4 | 3 | 3 | 3 |
| 6 | 12 | 6 | 6 | 4 | 3 | 2 | 2 | 2 |

| Models MCIF1501, 1501M, APIF150, 150M | | | | | | | | |
|--|----------------------|----|----|----|----|----|----|----|
| Persons in Family | IRON CONTENT - (PPM) | | | | | | | |
| | 2 | 4 | 6 | 8 | 10 | 12 | 14 | 16 |
| 1 | 12 | 12 | 12 | 12 | 12 | 12 | 12 | 12 |
| 2 | 12 | 12 | 12 | 12 | 12 | 12 | 6 | 6 |
| 3 | 12 | 12 | 12 | 12 | 6 | 6 | 6 | 4 |
| 4 | 12 | 12 | 12 | 6 | 6 | 6 | 4 | 4 |
| 5 | 12 | 12 | 12 | 6 | 6 | 4 | 4 | 3 |
| 6 | 12 | 12 | 12 | 6 | 4 | 4 | 4 | 3 |
| 7 | 6 | 6 | 4 | 4 | 4 | 3 | 2 | 2 |
| 8 | 6 | 4 | 4 | 4 | 3 | 2 | 2 | 2 |

| Models MCIF 2001, 2001M, APIF200, 200M | | | | | | | | | | | | |
|---|----------------------|----|----|----|----|----|----|----|----|----|----|----|
| Persons in Family | IRON CONTENT - (PPM) | | | | | | | | | | | |
| | 5 | 10 | 12 | 14 | 16 | 18 | 20 | 22 | 24 | 26 | 28 | 30 |
| 1 | 12 | 12 | 12 | 12 | 12 | 12 | 12 | 12 | 12 | 12 | 12 | 12 |
| 2 | 12 | 12 | 12 | 12 | 12 | 12 | 12 | 6 | 6 | 6 | 6 | 6 |
| 3 | 12 | 12 | 12 | 6 | 6 | 6 | 6 | 6 | 6 | 6 | 4 | 4 |
| 4 | 12 | 12 | 6 | 6 | 6 | 6 | 6 | 4 | 4 | 4 | 4 | 4 |
| 5 | 12 | 6 | 6 | 6 | 4 | 4 | 4 | 4 | 4 | 3 | 3 | 3 |
| 6 | 12 | 6 | 6 | 4 | 4 | 4 | 4 | 3 | 3 | 3 | 2 | 2 |
| 7 | 12 | 6 | 4 | 4 | 3 | 3 | 3 | 3 | 2 | 2 | 2 | 2 |
| 8 | 12 | 6 | 4 | 4 | 3 | 3 | 3 | 2 | 2 | 2 | 2 | 2 |
| 9 | 6 | 4 | 4 | 3 | 3 | 3 | 2 | 2 | 2 | 2 | 1 | 1 |
| 10 | 6 | 4 | 3 | 3 | 3 | 2 | 2 | 2 | 2 | 1 | 1 | 1 |

| Models MCIF 3001,3001M APIF 300, 300M | | | | | | | | | | | | |
|--|----------------------|----|----|----|----|----|----|----|----|----|----|----|
| Persons in Family | IRON CONTENT - (PPM) | | | | | | | | | | | |
| | 10 | 12 | 14 | 16 | 18 | 20 | 22 | 24 | 26 | 28 | 30 | 32 |
| 1 | 12 | 12 | 12 | 12 | 12 | 12 | 12 | 12 | 12 | 12 | 12 | 12 |
| 2 | 12 | 12 | 12 | 12 | 12 | 12 | 12 | 12 | 12 | 12 | 12 | 6 |
| 3 | 12 | 12 | 12 | 12 | 6 | 12 | 6 | 6 | 6 | 6 | 6 | 6 |
| 4 | 12 | 12 | 12 | 6 | 6 | 6 | 6 | 6 | 6 | 6 | 6 | 4 |
| 5 | 12 | 12 | 6 | 6 | 6 | 6 | 6 | 6 | 4 | 4 | 4 | 4 |
| 6 | 12 | 6 | 6 | 6 | 4 | 6 | 4 | 4 | 4 | 4 | 3 | 3 |
| 7 | 6 | 6 | 6 | 6 | 4 | 4 | 4 | 4 | 6 | 3 | 3 | 3 |
| 8 | 6 | 6 | 6 | 4 | 4 | 4 | 4 | 3 | 3 | 3 | 3 | 2 |
| 9 | 6 | 6 | 4 | 4 | 4 | 4 | 3 | 3 | 3 | 2 | 2 | 2 |
| 10 | 6 | 6 | 4 | 4 | 4 | 3 | 3 | 3 | 2 | 2 | 2 | 2 |

Step 18

The installation of your Chem-Free Iron Reduction System is now complete. If your water system installation is something other than a private well system, please familiarize yourself with the **SPECIAL INSTRUCTIONS FOR SPLIT STREAM AND PUBLIC WATER SUPPLY TYPE INSTALLATIONS ON page 3-13.**

HOW TO SET TIME OF DAY



STEP 1 - Press **SET HOUR** and release.

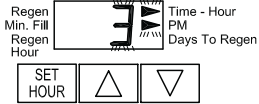

STEP 2 - Set the clock display to the closest hour by pressing the Δ or ∇ . An arrow will appear in the display pointing to **PM** during PM hours.



STEP 3 - Press **SET HOUR** to return to the display mode.

Note: After an extended power outage the time of day may need to be reset.

HOW TO MANUALLY INITIATE IMMEDIATE REGENERATION

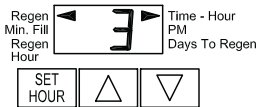

STEP 1 - Press and hold Δ and ∇ buttons simultaneously until valve motor starts (usually about three (3) seconds).

Note: Once a manual regeneration has been initiated, it cannot be stopped.

STEP 2 - Once the valve display is in **C1**, it is in **Backwash mode**. To advance to **Rapid Rinse** press and hold Δ and ∇ buttons simultaneously until valve motor starts (usually about three (3) seconds).

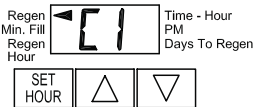

STEP 3 - Once the valve display is in **C4**, it is in **Rapid Rinse**. To advance to the display mode press and hold Δ and ∇ buttons simultaneously until valve motor starts (usually about three (3) seconds).

HOW TO MANUALLY INITIATE DELAYED REGENERATION

STEP 1 - Press and release the Δ and ∇ buttons simultaneously.



Note: An arrow will appear in the display pointing to **Regen** indicating regeneration will occur at the programmed time.

HOW TO CHANGE DAYS BETWEEN REGENERATION

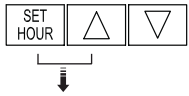

STEP 1 - Press and hold **SET HOUR** and Δ buttons simultaneously for three (3) seconds and release.

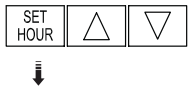

STEP 2 - Press **SET HOUR** button.

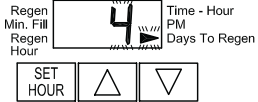

STEP 3 - Press Δ or ∇ buttons to change the number of days between regenerations.



STEP 4 - Press **SET HOUR** to return to the display mode.

Note: Your Chem-Free Iron Reduction filter is factory preset for 4 days between regenerations.

HOW TO CHANGE TIME OF REGENERATION

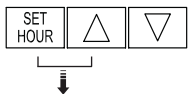

STEP 1 - Press and hold **SET HOUR** and Δ buttons simultaneously until the display begins flashing (usually about three (3) seconds).

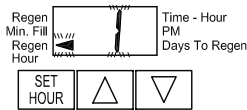

STEP 2 - Set the clock display to the closest hour by pressing Δ or ∇ button. An arrow will appear in the display pointing to **PM** during PM hours.

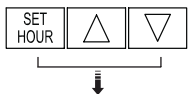

STEP 3 - Press and release **SET HOUR** and Δ buttons simultaneously to return to the display mode.

Note: Your Chem-Free Iron Reduction filter is factory set to regenerate at 1:00 AM.

HOW TO CHANGE THE REGENERATION PROGRAM SETTINGS

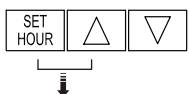

STEP 1 - Press and hold **SET HOUR** and Δ buttons simultaneously until the display begins flashing (usually about three (3) seconds).

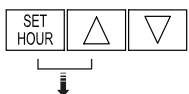

STEP 2 - Press and hold **SET HOUR** and Δ buttons simultaneously until the display begins flashing (usually about three (3) seconds).

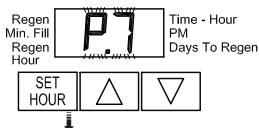

STEP 3 - Press the button to change the display to **P8** or **P9**.

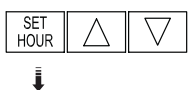

STEP 4 - Press the **SET HOUR** button five (5) times to return to the display mode. The time of day should be in the display.

Control Valve Function and Cycles of Operation

The AC adapter comes with a 15 foot power cord that is designed for use with the control valve. **The AC adapter is for dry location use only.** If the power goes out, only the time of day needs to be reset. All other settings are permanently stored in the non-volatile memory.

The following chart shows the time for the backwash and rapid rinse cycles for the three available programming options.

Regeneration Cycles and Times for Different Programs

| Program Number | Length of Cycle Times (Minutes) | |
|----------------|---------------------------------|------------------|
| | BACKWASH (C1) | RAPID RINSE (C4) |
| P7 | 6 | 4 |
| P8 | 10 | 6 |
| P9 | 14 | 8 |

Note: Your Chem-Free Iron Reduction Filter is factory preset to program number P7, changing the setting to P8 or P9 is rarely needed. But if a change is desired, please refer to ***“How to Change the Regeneration Program Settings”*** on page 3-10.

HOW TO SET TIMER CONTROL

Power Loss

If the power goes out, current time of day will need to be reset. If the power goes out while the system is regenerating, the cycle picks up where it was when the power went out.

Error Message

If "E1" "E2" or "E3" appears on the display, contact CUNO Water Treatment Technical Support Services @1-866-692-2543. These are error codes and will need to be resolved before the control valve will function. These codes indicate that the control valve did not function properly.



USER DISPLAYS

General Operation

When the system is operating, one of two displays will be shown. Pressing Δ or ∇ button will alternate between the displays. One of the displays is always the current time of day (to the nearest hour). The second display is the days remaining until the next regeneration. If the days remaining is equal to one, a regeneration will occur at the next preset regeneration time. The user can scroll between displays as desired.

If the system has called for a regeneration that will occur at the preset time of regeneration, the arrow will point to Regen.

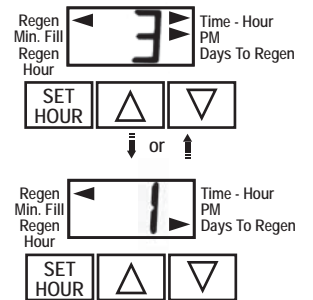

Regeneration Mode

Typically system is set to regenerate at a time of low water usage. Your Chem-Free Iron Reduction System is factory preset to regenerate at 1:00 AM. If there is a demand for water during the regeneration period, untreated water will be used.

When the system begins to regenerate, the display will change to indicate the cycle of the regeneration process that is occurring and an arrow will also point to **REGEN**. The system will run through the steps automatically and will reset itself to provide treated water when the regeneration is completed.

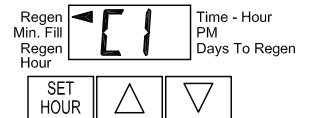

CAUTION

Installation must comply with state and local plumbing codes. Failure to follow installation, operation and maintenance instructions may result in property damage due to leakage and will void warranty.

Special Instructions For Split-Stream and Public Water Supply Type Installation:

For SPLIT-STREAM type installation, a secondary PRESSURE TANK must be installed as in Figure 1. On PUBLIC WATER SUPPLY type installations, a PRESSURE TANK must be installed as in Figure 1. It is recommended in both applications to use a standard air-to-water type pressure tank with air volume control (air release valve). The pressure tank should be of same capacity as would normally be installed if water systems were a standard private well type. Also note both applications require a **NORMALLY-CLOSED SOLENOID VALVE**. Follow standard installation procedures above with following additions and modifications.

- 1) Install PRESSURE TANK (SECONDARY PRESSURE TANK in Figure 1) as indicated by appropriate diagram.
- 2) Install NORMALLY-CLOSED SOLENOID VALVE, 110/120V, 60Hz after water meter and AFTER a line split for untreated water (if there is one).
- 3) On both types installation, install HYDRO-CHARGER between PRESSURE TANK (SECONDARY PRESSURE TANK on SPLIT-STREAM type installation) and NORMALLY-CLOSED SOLENOID VALVE.
- 4) Install PRESSURE SWITCH after HYDRO-CHARGER and wire it to SOLENOID VALVE (SECONDARY PRESSURE SWITCH on SPLIT-STREAM) Set HIGH pressure on PRESSURE SWITCH (which controls opening and closing of SOLENOID VALVE) 2 to 3 psi LOWER than LOW pressure on PRIMARY PRESSURE SWITCH. EXAMPLE: If PRIMARY PRESSURE SWITCH is set at 40/60 psi, set SECONDARY PRESSURE SWITCH at 20/38 psi.

For PUBLIC WATER SUPPLY type installations, contact your local water department or plant operator and ask what the normal LOW system pressure is. Set HIGH pressure on PRESSURE SWITCH 2 to 3 psi LOWER than this figure.

IMPORTANT NOTE

Failure to set PRESSURE SWITCH as described above will NOT allow proper closing of SOLENOID VALVE during periods of low system pressure. Improper function of SOLENOID VALVE will cause total failure of system.

Special Service Instructions:

Under normal circumstances removal of valve should never be required. However, if it must be removed, it can be done by disassembling the quick release clamp, by removing latch. Pressure should be relieved before attempting any disassembly. Upon reassembly, all O-rings should be lubricated with silicone grease. Reassemble clamp as shown in Figure 7. MAKE SURE ARROWS ON LATCH SIDE OF CLAMP ARE ALIGNED.

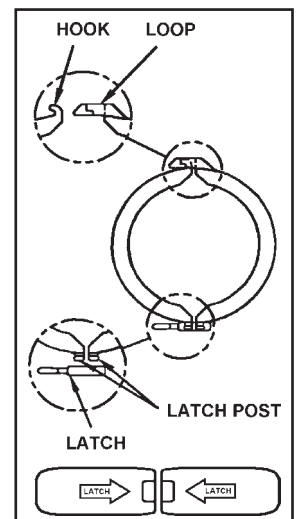

Figure 7

BYPASS VALVE OPERATION

Figure 8

NORMAL OPERATION

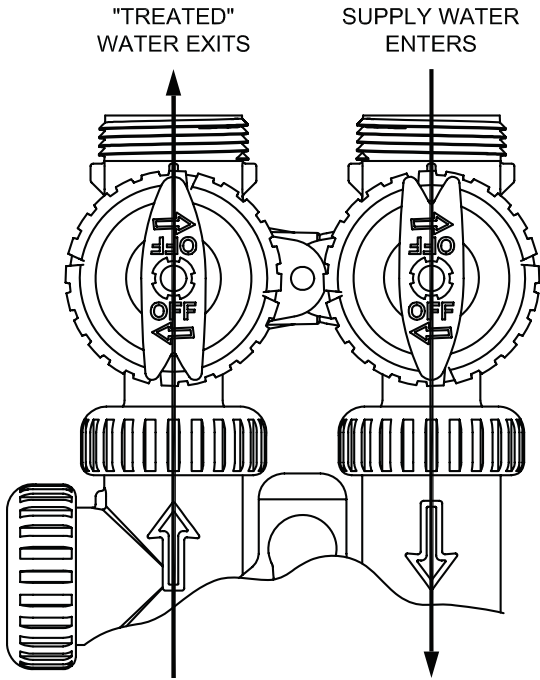

Figure 10

DIAGNOSTIC MODE

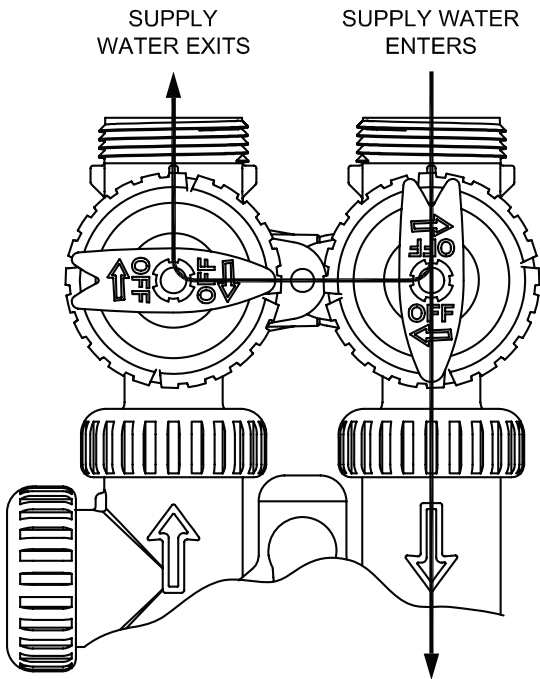

Figure 9

BYPASS OPERATION

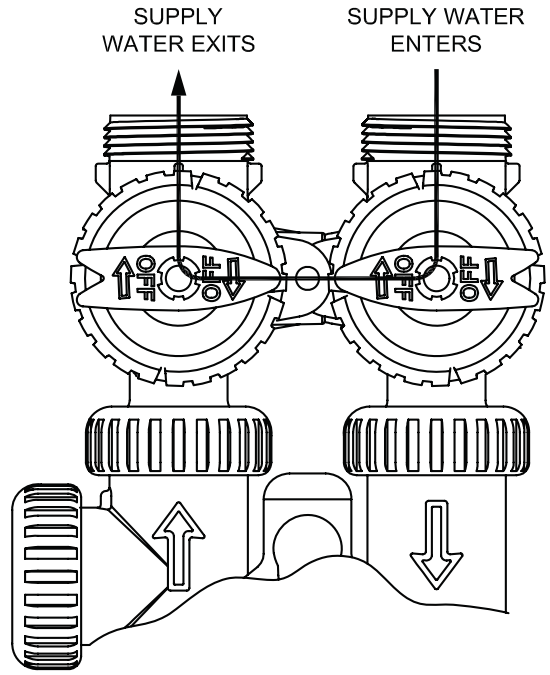
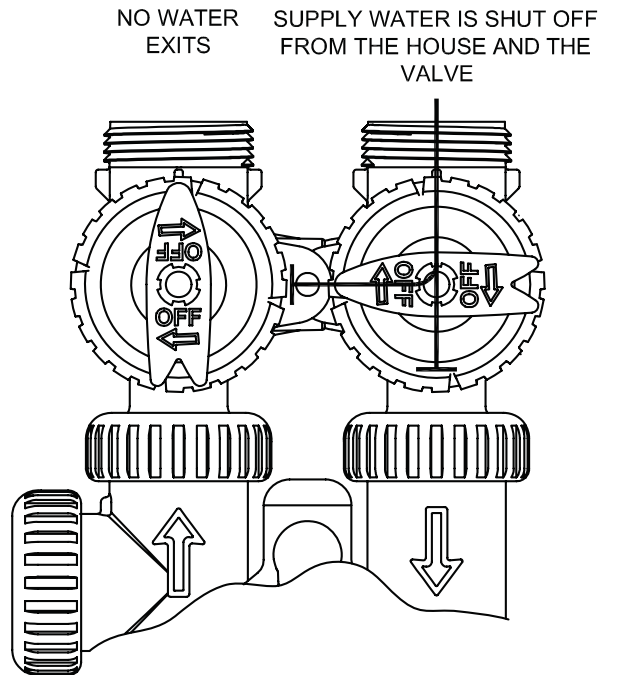

Figure 11

SHUT OFF MODE



SECTION 4: MAINTENANCE

The following procedures are guidelines only but have proven successful in most instances. Under no circumstances should any procedure outlined below be followed if contrary to the appliance manufacturer's instructions. Should there be any questions concerning the advisability of performing a procedure, it is strongly recommended the manufacturer's authorized service outlet be consulted prior to performing the procedure.

The plumbing system and water using appliances that have been exposed, even for a short time, to iron-fouled water need to be cleaned of the precipitated iron that has collected in them or iron "bleed" (staining) will continue to be a problem.

Depending on the amount of iron in the water and the length of time the water system has been exposed to iron fouling, select the following procedures that apply to the type of system and appliances that need cleaning to help assure better quality water at the points of use.

It is not uncommon that a softener was installed in an effort to reduce ferrous ("clear water") iron from the water supply. Typically, a softener will reduce some ferrous iron until the resin bed becomes fouled to the extent that it will lose both hardness reduction capacity and the limited capacity for iron removal. This is the condition to expect the softener to be in when planning a system clean-up.

Prior to closing main supply valve or turning power off to a private well system and preparatory prior to installing the Chem-Free Iron Reduction System on a system where a softener has already been installed, do the following:

- 1) Disconnect brine draw line from brine tank and place the loose end into a five gallon plastic pail filled with a solution of hot water and 10 ozs. of resin mineral cleaner (IRON-X).
- 2) Manually advance control timer to BRINE DRAW position (refer to instructions provided with your softener), and allow all hot mineral cleaner solution to be drawn into mineral bed. Then IMMEDIATELY:
- 3) Close main water supply valve or turn power off to pump and proceed with filter installation. During time required to install filter system, iron-fouled softener resin will be chemically cleaned.
- 4) After filter installation is completed, final adjustments made with water turned and the brine draw tube reconnected, manually reposition timer on softener to BACK-WASH position. Allow timer to perform an automatic complete backwash and regeneration cycle. During backwashing of softener, iron cleaned from the resin will be washed down drain. It is advisable after chemically cleaning softener to regenerate system twice to fully restore capacity lost due to iron-fouling.

Water Heater

If the water heater has been exposed to both iron and hardness for a long period of time, replacement of the heater tank may be the only practical solution to prevent continued staining originating from the source.

After completing the installation of the Chem-Free Iron Reduction System, clean the water heater by following these instructions:

- 1) Shut off fuel supply to water heater and close heater inlet water valve.
- 2) Drain hot water tank completely. Open inlet water valve allowing heater tank to be refilled with iron-free water. Continue flushing until water runs clear to drain.
- 3) If after approximately 30 minutes flushing, water does NOT clear, terminate flushing operation. Refill water heater with water and pour approximately 1/2 gallon of household bleach into top of heater tank. Allow bleach solution to stand in tank for 20 to 30 minutes. Flush tank again until water is clear at drain. Turn fuel supply on.

Note: If water does not clear in approximately 10 minutes, water heater probably should be replaced.

Dishwasher

Consult owner's handbook and follow manufacturer's instructions.

Toilet Flush Tanks

Prior to commencing installation of the Chem-Free Filter System, pour 4 to 6 ounces of resin mineral cleaner (IRON-X) or inhibited muriatic acid into flush tanks and bowls and let stand. When installation is completed, flush toilets several times with iron-free water. If iron deposits or stains remain, repeat procedure until clear.

SECTION 5: Backwashing Instructions

Periodic Backwashing of the Chem-Free Filter System bed is required to flush out the entrapped iron that has accumulated. This procedure is performed automatically at 1:00 a.m. for a period of approximately 10 minutes and will not interfere with a softener regeneration, which is usually set for 2:00 a.m.

TO SET BACKWASH FREQUENCY FOR NORMAL HOUSEHOLD APPLICATIONS:

To determine and set Backwash Frequency, follow these instructions:

- 1) Select Backwash Frequency Schedule corresponding to your model (page 3-7 and 3-8).
- 2) Locate box intersected by number of persons in your family and iron concentration of water (if iron concentration is between two numbers in Schedule, use higher number.)
- 3) Number in box represents number of days, between regenerations. Refer to How to Change Days Between Regeneration on page 3-10.

Example: You have model MCIF1001 or APIF100, 4 people in family, and 8 ppm iron. Refer to Schedule for model MCIF1001 or APIR100 and locate box intersected by 4 in family and 8 ppm iron. The figure indicates the number of days between each regeneration period.

IMPORTANT NOTES

The Backwashing Frequency Schedules are based on average water consumption rates and are merely guides. They are NOT intended to be used if water is used by outside spigots, a swimming pool, geothermal heat pump, or other high water usage devices or activities. If your application includes any of these, and you have already determined your model Chem-Free System is capable of handling the flow rates involved, refer to the next paragraph for instructions on setting Backwash Frequency.

TO SET BACKWASH FREQUENCY FOR COMMERCIAL MODELS AND NON-STANDARD HOUSEHOLD APPLICATIONS:

If your filter is to be used for a commercial application or for reasons covered above, the Backwashing Frequency Schedule is not applicable. Determine the backwashing frequency as follows:

- 1) Estimate Daily Iron Reduction by multiplying iron concentration by estimated daily water consumption (use 60 gallons per person per day for normal household applications):

Est. Daily Water Usage _____ gal. X Iron Concentration _____ ppm =

Daily Iron Reduction _____ (ppm - gal.)

- 2) Calculate Backwash Frequency by inserting Daily Iron Reduction from above into following formula (refer to specifications for Iron Reduction Capacity of your model):

Iron Reduction Capacity of Model _____ (ppm-gal.) ÷ Daily Iron Reduction _____ (ppm - gal.) =

Backwashing Frequency _____ days

If your water contains high iron concentration, manganese, tannins, or hydrogen sulfide, it may be advisable to increase the backwash frequency to daily, if necessary. It should be noted, however, that increasing the frequency or duration of backwashing WILL NOT overcome an insufficient pumping rate.

SECTION 6: TROUBLESHOOTING - CONTROL VALVE

| Problem | Cause | Solution |
|--|---|---|
| 1. Timer does not display time of day | a. AC adapter unplugged | a. Connect power |
| | b. No electric power at outlet | b. Repair outlet or use working outlet |
| | c. Defective AC adapter | c. Replace C Adapter |
| | d. Defective PC board | d. Replace PC board |
| 2. Timer does not display correct time of day | a. Switched outlet | a. Use an unswitched outlet |
| | b. Time of day not set correctly | b. Reset time of day |
| 3. Control Valve regeneration at wrong time of day | a. Power outages | a. Reset control valve to correct time of day |
| | b. Time of day not set correctly | b. Reset to correct time of day |
| | c. Time of regeneration incorrect | c. Reset regeneration time |
| 4. Error followed by a code number Error code E1- Unable to recognize start of regeneration Error code E2- Unexpected stall Error code E3- Motor ran too long. Timed out trying to reach next cycle position If other codes appear contact factory | a. Control valve has just been serviced | a. Press SET HOUR and DOWN for 3 seconds or unplug power source jack (black wire) from the circuit board and plug back in to reset control valve |
| | b. Foreign matter is lodged in control valve | b. Check piston and spacer stack assembly for foreign matter |
| | c. High drive forces on piston | c. Replace piston(s) and spacer stack assembly |
| | d. Control valve piston not in home position | d. Press SET HOUR and DOWN for 3 seconds or unplug power source jack (black wire) from the circuit board and plug back in to reset control valve. |
| | e. Motor not inserted fully to engage pinion, motor wires broken or disconnected, motor failure | e. Check motor and wiring. Replace motor if necessary |
| | f. Drive gear label dirty or damaged, missing or broken gear | f. Replace or clean drive gear |
| | g. Drive bracket incorrectly aligned to drive bracket | g. Reseat drive bracket properly |
| | h. PC board incorrectly aligned to drive bracket | h. Replace PC board |
| | i. PC board incorrectly aligned to drive bracket | i. Ensure PC board is correctly snapped on to drive bracket |
| 5. Control valve stalled in regeneration | a. Motor not operating | a. Replace motor |
| | b. No electric power at outlet | b. Repair outlet or use working outlet |
| | c. Defective AC adapter | c. Replace AC adapter |
| | d. Defective PC board | d. Replace PC board |
| | e. Broken drive gear or drive cap assembly | e. Replace drive gear or drive cap assembly |
| | f. Broken piston retainer | f. Replace piston retainer |
| | g. Broken main or regerant piston | g. Replace main or regenerant piston |
| 6. Control valve does not regenerate automatically when UP and DOWN buttons are depressed and held. | a. AC adapter unplugged | a. Connect AC adapter |
| | b. No electric power at outlet | b. Repair outlet or use working outlet |
| | c. Broken drive gear or drive cap assembly | c. Replace drive gear or drive cap assembly |
| | d. Defective PC board | d. Replace PC board |
| 7. Control valve does not regenerate automatically, but does when UP and DOWN buttons are depressed and held | a. Defective PC board | a. Replace PC board |
| | b. Set-up error | b. Check control valve set-up procedure |

SECTION 6: TROUBLESHOOTING - FILTER UNIT

| Problem | Cause | Solution |
|--|---|---|
| 1. Water CLEAR when drawn, turns RED upon standing (Stain producing) | a. Insufficient air-draw by Hydro-Charger. | a. Check Hydro-Charger adjustment. If unable to adjust for long enough draw, check pumping rate. |
| | b. Bypass open or leaking | b. Close bypass valve and/or repair as necessary. |
| | c. Filter bed overloaded with precipitated iron due to insufficient backwash, or failure to backwash due to malfunction of control timer or unplugged control valve power cord. | c. Upon correction of problem (increase backwash frequency if problem determined to be insufficient frequency), manually backwash until backwash water starts to clear (in more severe iron fouling cases, filter bed may need chemical cleaning - contact dealer). |
| | d. Presence of manganese or tannins. | d. Recheck water analysis |
| | e. Flow rate excessive for model. | e. Reread Sec. 2, FACTS TO REMEMBER WHILE PLANNING YOUR INSTALLATION. |
| | f. Check-valve located between Hydro Charger and pressure tank, disrupting water flow. | f. Relocate check-valve. |
| | g. Pumping cycle too short, limiting residence time in pressure tank (may be water-logged). | g. Correct condition. |
| | h. pH of treated water too low (should be 7.0 or higher; with manganese, pH must be 8.2). | h. Replenish MpH Adder component in media (contact dealer). |
| 2. Water RED when drawn from tap | a. Filter bed overloaded with precipitated iron due to insufficient back-wash flow rate. | a 1. Recheck well pumping rate and repair or replace as required. 2. Check for obstructions or kink in drain line. 3. Check for improper drain line flow controller (see specs.) Upon correction of this problem, if manually backwashing does not clear bed of iron, filter bed may need chemical cleaning - contact dealer. |
| | b. Filter bed over loaded with precipitated iron due to insufficient back-wash, or failure to backwash due to malfunction of control timer or unplugged control valve power cord. | b. Upon correction of problem (increase backwash frequency if problem determined to be insufficient frequency), manually backwash until backwash water starts to clear (in more severe iron-fouling cases, filter bed may need chemical cleaning - contact dealer). |
| | c. Hydro-Charger drawing too much air, causing early precipitation of iron. | c. Reduce Hydro-Charger air-draw. |
| | d. Hydro-Charger installed too far from pressure tank or pressure tank located too far from filter tank causing iron to precipitate before filter tank. | d. Relocate to a location closer to filter inlet. |
| | e. Solenoid valve (SPLIT-STREAM or PUBLIC WATER SUPPLY type installation) malfunction or inadequate supply system pressure/flow rate. | e. Repair or replace solenoid valve and verify adequate supply system pressure and flow rate. |
| | 3. Excessive pressure loss through filter | a. Filter bed overloaded with precipitated iron. |
| | b. Control inlet/outlet valve(s) not fully open. | b. Open as necessary. |
| | c. Sand, silt or mud collecting in filter bed. | c. Check well for these conditions. |
| | d. Filter bed not properly "classified." | d. Manually backwash to reclassify. |
| | e. "Cementing" or "channeling" of filter media. | e. Prod (stir) filter bed to break up hardened layer. Increase backwash frequency to prevent reoccurrence. |
| 4. "Milky" or "bubbly" water (Appears to contain small bubbles) | a. Excess Hydro-Charger air-draw. | a. Check adjustment for duration of draw in excess of one-third pumping cycle (see Sec.3, Step 10). |
| | b. Excess gases in water (carbon dioxide, hydrogen sulfide, methane). | b. May require draining of water system or installation of air-relief control on the fill port cap of valve adapter base, (contact dealer). |

SECTION 7: VALVE SPECIFICATION AND OPERATING DATA

| | | | | |
|--|--|-----------------------------------|--------------------------|--------------------------|
| Maximum Service Flow Rate: Includes Bypass Valve | 27 gpm (102.2 lpm) @15 psig (103 kPa) drop | | | |
| Maximum Backwash Flow Rate: Includes Bypass Valve | 27 gpm (102.2 lpm) @15 psig (103 kPa) drop | | | |
| Minimum/Maximum Operating Pressure: | 20 psi (138 kPa) - 125 psi (862 kPa) | | | |
| Minimum/Maximum Operating Temperature: | 40°F (4.4°C) - 110°F (43.3° C) | | | |
| AC Adapter: Supply Voltage Supply Frequency Output Voltage Output Current | U.S. 120 V. AC 60 Hz 12 V. AC 500 mA | | | |
| Drain Line Flow Control | Unit Size | Number on Drain Line Flow Control | Backwash Flow Rate (gpm) | Backwash Flow Rate (lpm) |
| | .75 ft ³ | 032 | 3.2 | 12.1 |
| | 1.0 ft ³ | 053 | 5.3 | 20.1 |
| | 1.5 ft ³ | 053 | 5.3 | 20.1 |
| | 2.0 ft ³ | 075 | 7.5 | 28.4 |
| | 3.0 ft ³ | 100 | 10.0 | 37.9 |
| Inlet/Outlet Tube Opening | (a) 1" Universal Elbow (b) 1" Straight brass sweat fitting (c) 1" Plastic male NPT fitting | | | |
| Distributor Tube Opening | 1.05" OD (3/4 NPS) | | | |
| Tank Thread | 2 1/2"- 8 NPSM to Flanged Adapter | | | |
| Control Valve Weight | 4.5 lbs. (2.0 kg) | | | |
| PC Board Memory | Nonvolatile EEPROM (electronic erasable programmable read only memory) | | | |

Note: After completing any valve maintenance involving the drive assembly or the drive cap assembly and pistons, unplug the power source from the jack on the printed circuit board (black wire) and plug back in. This resets the electronics and establishes the service piston position.

SECTION 7: SPECIFICATION AND OPERATING DATA

| ITEM | APIF075 APIF175M MCIF0751 MCIF0751M | APIF100 APIF100M MCIF1001 MCIF1001M | APIF150 APIF150M MCIF1501 MCIF1501M | APIF200 APIR200M MCIF2001 MCIF2001M | APIF300 APIF300M MCIF3001 MCIF 3001M |
|---|--|--|--|--|---|
| Media Volume, cu. ft. (cu. mtr.) (Note 1): | 0.75 (0.02) | 1.0 (0.03) | 1.5 (0.04) | 2.0 (0.06) | 3.0 (0.08) |
| Gravel Underbed, lbs. (kg) | 9 (4.1) | 13 (5.9) | 13 (5.9) | 18 (8.2) | 26 (11.8) |
| Nominal Capacity, ppm-gal. | 22,500 | 30,000 | 45,000 | 60,000 | 90,000 |
| Operating Flow Rate, gpm (lpm) (Note 2): | | | | | |
| Continuous | 2 (7.6) | 3 (11.4) | 3 (11.4) | 4 (15.1) | 5 (18.9) |
| Service | 4 (15.2) | 6 (22.7) | 7 (26.5) | 9 (34.1) | 12 (45.5) |
| Pressure Loss @ Flow Rates, psi (kPa) | | | | | |
| Continuous | 1 (6.9) | 2 (13.8) | 2 (13.8) | 2 (13.8) | 2 (13.8) |
| Service | 4 (27.6) | 5 (34.5) | 7 (48.2) | 8 (55.1) | 10 (68.9) |
| Backwash Flow Rate, gpm (lpm) Note 3 | 3.2 (12.1) | 5.3 (20.1) | 5.3 (20.1) | 7.5 (28.4) | 10 (37.9) |
| Service Pipe Size, in. (cm) (Note 4) | 1 (2.5) | 1 (2.5) | 1 (2.5) | 1 (2.5) | 1 (2.5) |
| Filter Tank Diameter x Height, in. (cm) | 8 x 44 (20 x 112) | 10 x 44 (26 x 112) | 10 x 54 (26 x 137) | 12 x 54 (30 x 137) | 14 x 65 (36 x 165) |
| Minimum Space Required, in. (cm): | | | | | |
| Width | 12 (30) | 12 (30) | 12 (30) | 12 (30) | 13 (33) |
| Depth (w/Bypass) | 16 (41) | 16 (41) | 16 (41) | 16 (41) | 16 (41) |
| Height | 53 (135) | 53 (135) | 63 (160) | 63 (160) | 74 (188) |
| Approximate Shipping Weight, lbs. (kg) | 116 (52.6) | 143 (64.9) | 186 (84.4) | 257 (116.6) | 353 (160.2) |
| Maximum Operating Temperature 100°F (38°C); Electrical requirements 110V/60Hz; Operating Pressure 20 -100 psi (138-689 kPa). Specifications subject to change without notice. | | | | | |

IMPORTANT NOTES

- 1) Replenishment of pH adjusting component of media may be required periodically, the frequency of which is dependent on raw water pH, manganese concentration and water consumption rate. Consult dealer for more information.
- 2) For satisfactory performance, indicated durations should not be exceeded. Flow rates specified are adequate for normal residential applications. Do not use Service or Peak flow rates when sizing commercial applications or if treated water is to supply a geothermal heat pump, swimming pool, etc. (contact dealer before selecting equipment). Service flow rates have been tested against NSF Standard 42 and have a rated pressure drop of less than 10 psi.
- 3) For system to operate properly, pumping rate of well pump MUST be sufficient to backwash unit at rate specified.
- 4) Service Pipe size is 3/4" on models not shown above: MCIF0750, 0750M, 1000, 1000M, 1500, 1500M, 2000, 2000M, 3000 and 3000M.

SECTION 7: COMPONENTS ASSEMBLIES

CHEM-FREE IRON FILTER ASSEMBLIES AND COMPONENTS DRIVE CAP ASSEMBLY, DOWNFLOW PISTON, AND SPACE STACK ASSEMBLIES

| Reference No. | Part No. | Description | Quantity |
|---------------|----------|--------------------------|----------|
| 1 | V3005 | Spacer Stack Assembly | 1 |
| 2 | V3004 | Drive Cap Assembly | 1 |
| 3 | V3178 | Drive Back Plate | 1 |
| 4 | V3001 | Piston Downflow Assembly | 1 |
| 6 | V3135 | O-ring 228 | 1 |
| 7 | V3180 | O-ring 337 | 1 |
| 8 | V3105 | O-ring 215 Pilot Tube | 1 |
| NOT SHOWN | V3001 | Downflow body Assembly | 1 |

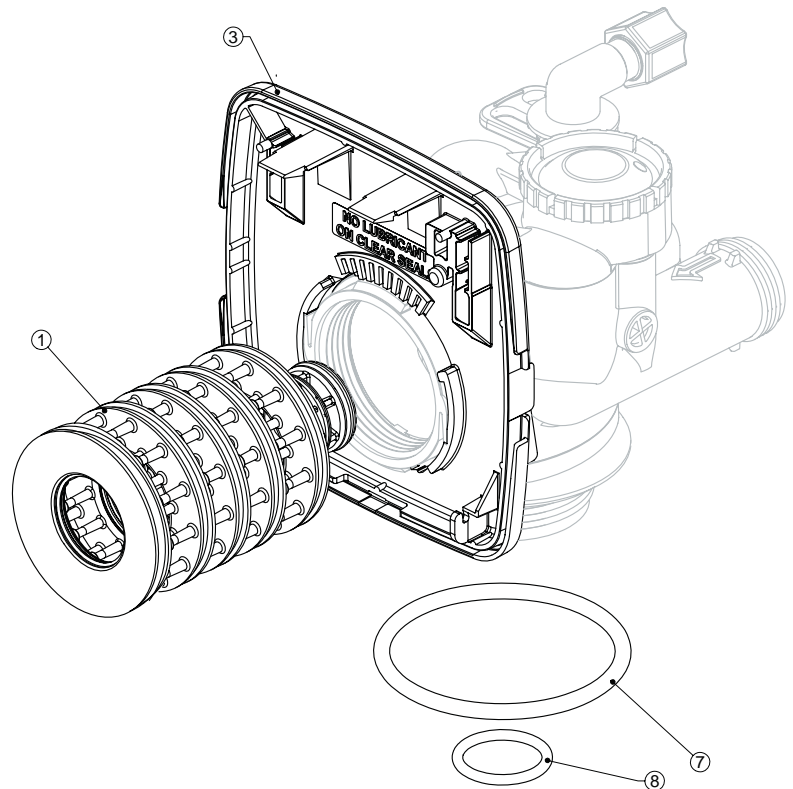
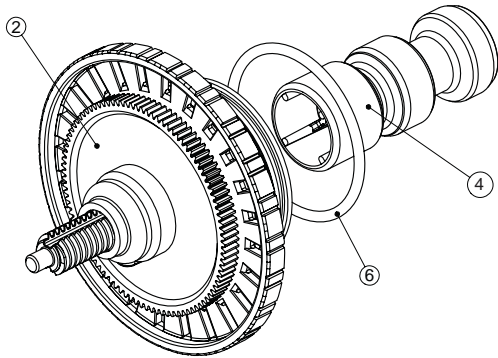

SECTION 7: FRONT COVER AND DRIVE ASSEMBLY

| Reference No. | Part No. | Description | Quantity |
|---------------|------------|---------------------------------|----------|
| 1 | V3175TC-01 | Time Clock Front Cover Assembly | 1 |
| 2 | V3107-01 | Motor | 1 |
| 3 | V3106-01 | Drive Bracket & Spring Clip | 1 |
| 4 | V3108TC | Time Clock PC Board | 1 |
| 5 | V3110 | Drive Gear 12 x 36 | 1 |
| 6 | V3109 | Time Clock Cover | 1 |
| | V3002TC | Time Clock Drive Assembly | 1 |
| NOT SHOWN | V3186 | AC Adapter 110V - 12V | 1 |

Drawing number parts 2 through 6 may be purchased as a complete assembly, part V3202.

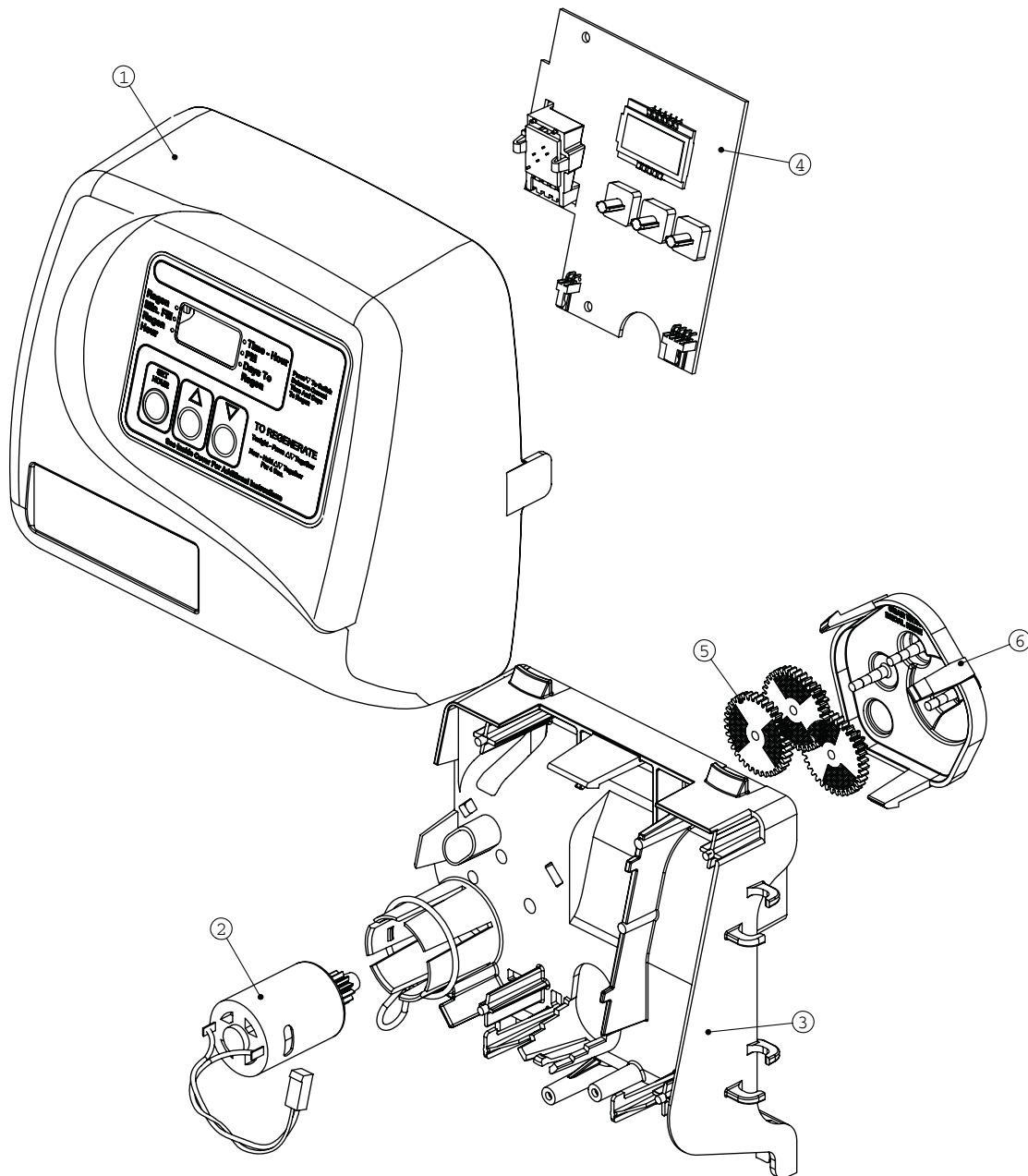

SECTION 7: QUICK CONNECT BYPASS Part Number V3006

| Reference No. | Part No. | Description | Quantity |
|---------------|----------|----------------------|----------|
| 1 | V3151 | Nut 1" Quick Connect | 2 |
| 2 | V3150 | Split Ring | 2 |
| 3 | V3105 | O-ring | 2 |

Not Shown Part# V3191-01 Vertical Bypass Adapter

| | | |
|-------|-------------------------|---|
| V3151 | 1" Quick Connect Nut | 2 |
| V3150 | Split Ring | 2 |
| V3105 | O-ring 215 | 2 |
| V3191 | Vertical Bypass Adapter | 1 |

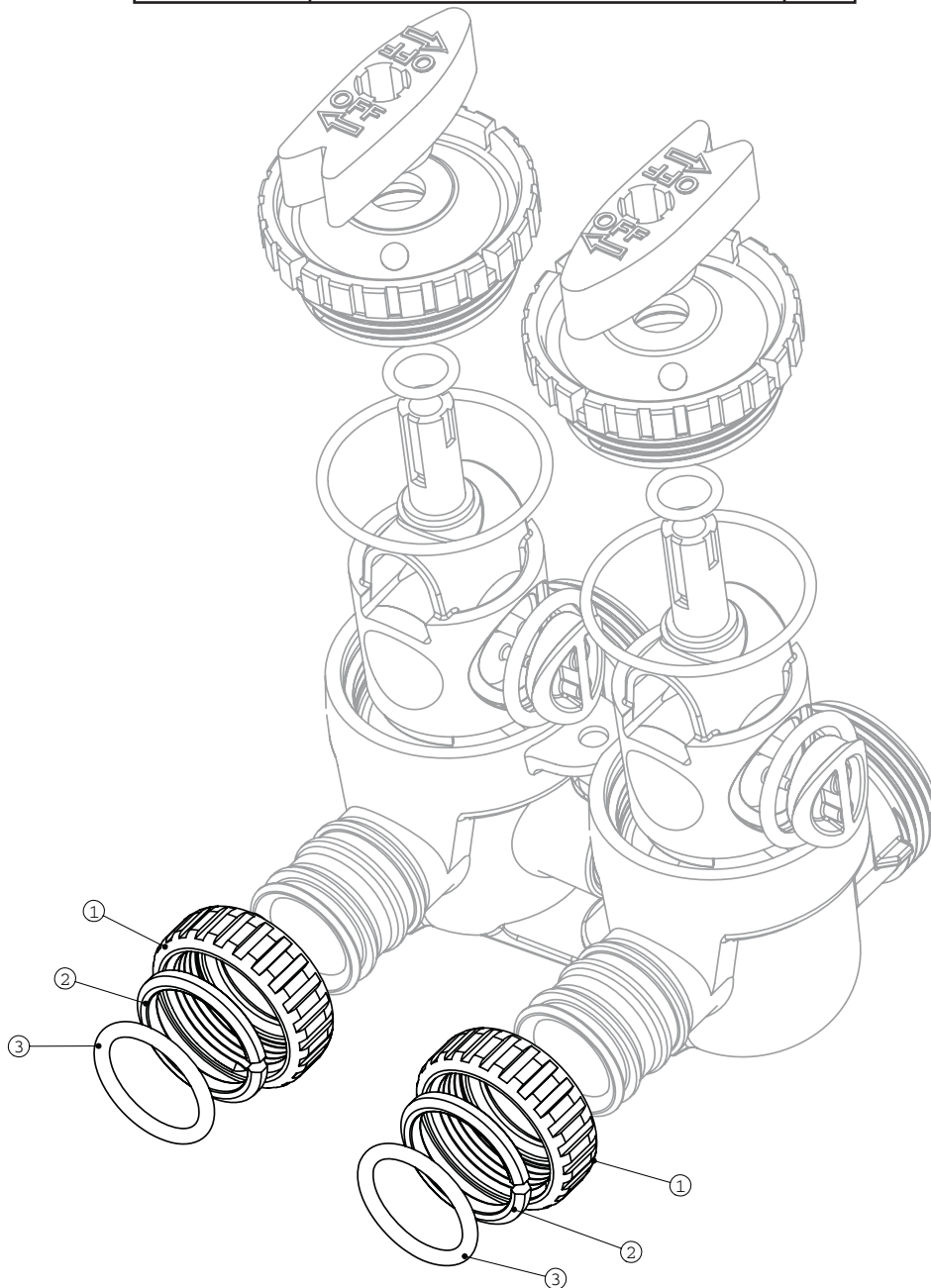

SECTION 7: INSTALLATION FITTING AND ASSEMBLIES

Quick Connect Assemblies

Part # V3007-02

1" Copper Brass Sweat Adapter

| Reference No. | Part No. | Description: 1" Brass Sweat Assembly | Quantity |
|---------------|----------|---------------------------------------|----------|
| 1 | V3151 | 1" Quick Connect Nut | 2 |
| 2 | V3150 | 1" Quick Connect Split Ring | 2 |
| 3 | V3105 | 1" Quick Connect O-Ring 215 | 2 |
| 4 | V3188 | 1" Quick Connect Brass Sweat Assembly | 2 |

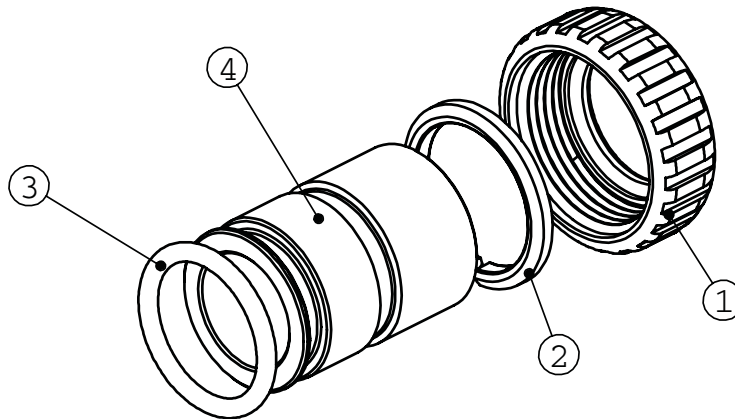

Part # V3007-04

1" Plastic Male NPT Assembly

| Reference No. | Part No. | Description | Quantity |
|---------------|----------|--|----------|
| 1 | V3151 | 1" Quick Connect Nut | 2 |
| 2 | V3150 | 1" Quick Connect Ring | 2 |
| 3 | V3105 | 1" Quick Connect O-Ring 215 | 2 |
| 4 | V3164 | 1" NPT Quick Connect Plastic Male Assembly | 2 |

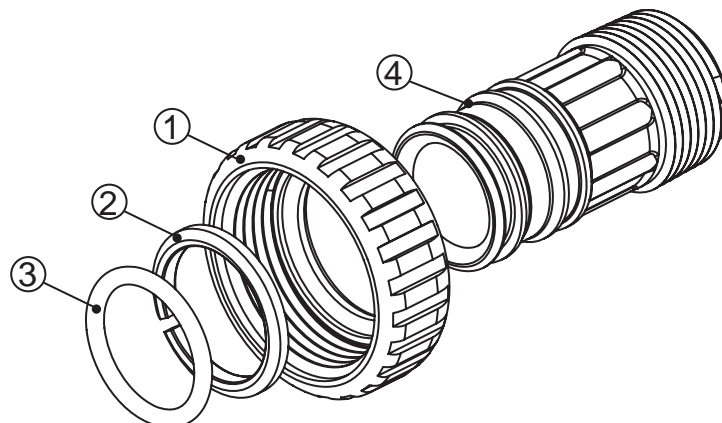

| Reference No. | Part No. | Description | Quantity |
|---------------|---------------|---|----------|
| 1 | H4615 | Elbow Locking Clip | 1 |
| 2 | PKP10T58S-BLK | 5/8" Insert Sleeve | 1 |
| 3 | V3192 | Quick Connect 3/4" Drain Elbow Nut | 1 |
| 4 | V3158-01 | Quick Connect 3/4" Drain Elbow | 1 |
| 5 | V3163 | O-ring 019 | 1 |
| 6 | V3159-01 | Drain Line Flow Control Retainer Assembly | 1 |
| 7 | V3162-042 | 4.2 gpm Drain Line Flow Control Button | 1 |
| 7 | V3162-053 | 5.3 gpm Drain Line Flow Control Button | 1 |
| 7 | V3162-075 | 7.5 gpm Drain Line Flow Control Button | 1 |
| 7 | V-3262-100 | 10.0 GPM Drain Line Flow Control Button | 1 |

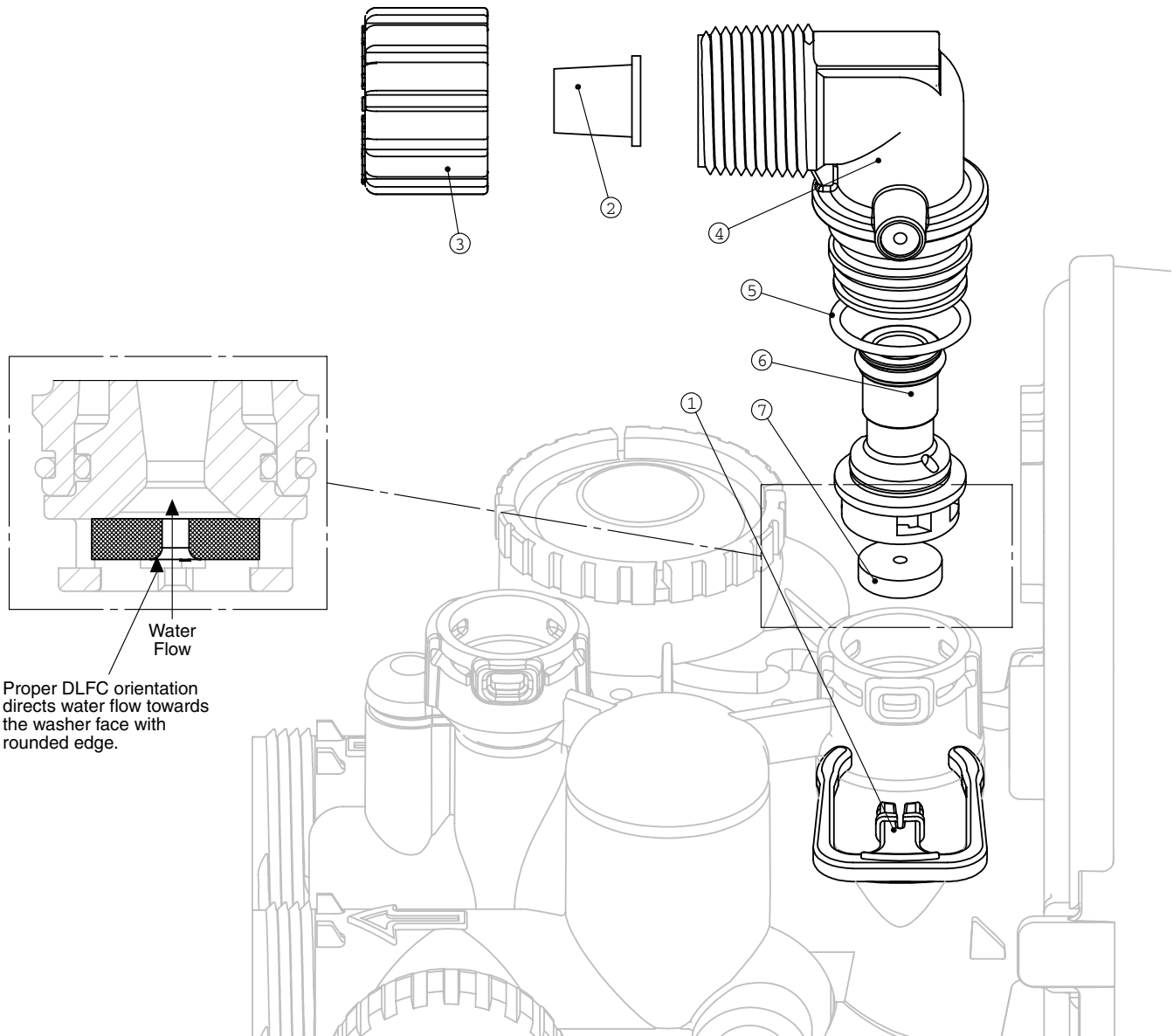

SECTION 8: MAINTENANCE

Depending on your water quality, it may be necessary to perform maintenance on your filter system in order to ensure continued performance. This is to both low pH, high manganese and the sacrificial nature of the filter media. The severity of your pH or the amount of water used will determine how often the filter will need to be serviced. To correct this condition, it will be necessary to add MPH adder to the filter bed. The part number is MPH04, and can be purchased as a single unit or in a case of 6, which is MPH0406. Either of these items can be purchased through our wholesale chain in your area. MPH0406 is a 3 ½ pound jar of pH boosting material that replenishes the same material that was dissolved into your water to make Iron and Manganese reduction possible.

CUNO Incorporated recommends that you test your treated water pH once a quarter. When Iron is the only problem, a water pH needs to be 7.2 higher. When Manganese and Iron are present, the treated water pH needs to 8.2 or higher. The levels can be checked on location with the use of an inexpensive pH test kit that can be purchased locally or from CUNO. Our part number is “17N” . When the pH falls below the recommended level and Iron or Manganese is bleeding through into the finished water, it is time to add the MPH adder component to the filter. The amount of material to add to a filter is as follows.

Standard bed filters (identified by an “S” in the model number, i.e. APIF100 or no “S”, i.e. MCIF1001)
 1- 3 ½ pound jar of MPH adder for each cubic foot of filter material

Manganese bed filters (Identified by an “M” in the model number, i.e APIF100M or MCIF1001M)
 2- 3 ½ pound jars of MPH adder for each cubic foot of filter material.

| Bed Type | Filter Models (Number of Jars to Add) | | | | |
|-------------------------------|--|------------------------------|--------------------------------|------------------------------|------------------------------|
| Standard Filter Media | MCIF0751 APIF075 (1) | MCIF1001 APIF100 (1) | MCIF1501 APIF150 (1 ½) | MCIF2001 APIF200 (2) | MCIF3001M APIF300 (3) |
| Manganese Filter Media | MCIF0751M APIF075M (1) | MCIF1001M APIF100M (1) | MCIF1501M APIF150M (1 ½) | MCIF2001M APIF200M (2) | MCIF3001M APIF300M (3) |

Step by step procedure to add MPH adder to your Chem-Free Free Iron Filter.

- 1) Turn the inlet and outlet knobs of the bypass valve located on the back side of the control valve. See figure 4 in section 3 for proper orientation.
- 2) Manual initiate a backwash cycle to relieve water pressure from the inside of the filter.
- 3) Disconnect the drain line and set aside.
- 4) Remove the latch on the clamp assembly and separate the clamp assembly. Set aside in a secure location for reuse.
- 5) Slowly lift the control valve straight up and off the filter vessel. Do not rock the control from side to side as this might damage the controller or distributor tube.
- 6) Using the funnel and centering device supplied with the unit originally, install over the distributor tube and inside the opening of the filter vessel to aid in adding the MPH adder material.
- 7) Using a ½ diameter flexible tubing siphon about 12” of water from the filter vessel to allow for adding the MPH adder.

- 8) Pour the recommended amount of MPH adder into the filter media and add water back to filter to expel any air pockets in the filter vessel.
- 9) Reinstall the control valve back on top of filter vessel. You may want to apply some silicone lubricant to the O-rings, distributor tube and the inside of the filter vessel opening to facilitate for easier installation. Allow the control valve to rest on the filter vessel flange and with one steady downward motion push the control into the vessel opening to seat properly. Manually stage control valve to the service position. **Refer to Section 5, "HOW TO MANUALLY INITIATE IMMEDIATE REGENERATION"**.
- 10) Reinstall the clamp assembly around both the control valve and filter vessel flange and secure the latch. See Figure 7 for proper orientation in Section 3.
- 11) Connect both the bypass and the drain line to the control valve and hand tighten only the connection nuts.
- 12) Slowly open the inlet side of the bypass and pressurize the filter, check for leaks, correct if necessary.
- 13) Slowly open the outlet side of the bypass and pressurize the dwelling.
- 14) Manual stage the control to backwash and clean the filter media of any fines that would be present till clear. Allow the control to complete regeneration cycle completely and return to service. **Refer to Section 5, "HOW TO MANUALLY INITIATE IMMEDIATE REGENERATION"**.

Limited Warranty

Please read and complete the following warranty and mail the bottom half within 10 days of purchase

CUNO Incorporated warrants to the original purchaser-consumer of its Product that it is free of defects in materials and workmanship. Any defect, malfunction, or other failure of this product to conform to this Warranty will be remedied by CUNO in the manner provided below.

This Warranty, together with any and all warranties implied by law, shall be limited to a duration described herein, from the date of purchase by the consumer with the following exclusions and limitations as follows:

- One year on entire unit
- Five years on mineral tank only
(does not include internal components)
- Five years on control valve body only
(does not include internal or external components)
- Five years on salt storage container and components.*

This Warranty does not apply to defects that result from abuse, misuse, alterations or damage not caused by CUNO.

IMPORTANT: To file a claim under this warranty you must complete and mail the Warranty registration card supplied with this Product to CUNO at the address below within ten (10) days of original retail purchase.

CUNO Incorporated, 12628 U.S. 33 North, Churubusco, IN U.S.A.

THIS WARRANTY DOES NOT COVER, AND IS INTENDED TO EXCLUDE, ANY LIABILITY ON THE PART OF CUNO, WHETHER UNDER THIS WARRANTY OR UNDER ANY WARRANTY IMPLIED BY LAW, FOR ANY INDIRECT OR CONSEQUENTIAL DAMAGES FOR BREACH HEREOF OR THEREOF.

Note: Some states prohibit limitations on the duration of implied warranties and on the exclusion of indirect or consequential damages, and so the above limitation on implied warranties and on incidental and consequential damages may not be applicable to you.

RESPONSIBILITY OF CUNO

CUNO's responsibility under this warranty shall be to repair at its expense, and at no charge to the original purchaser-consumer, any Product that is actually defective, malfunctioning, or otherwise in violation of this Warranty.

If CUNO, for any reason, cannot repair a Product covered hereby within two (2) weeks after inspection of the unit by CUNO or its authorized representative, then CUNO's responsibility shall be, at its option, either to replace the defective Product with a comparable new unit at no charge to the consumer or to refund the full purchase price. CUNO's obligations of repair, replacement, or refund are conditioned upon the consumer's making the product available for inspection by CUNO or its authorized representative.

If any Product covered hereby is actually defective within the terms of this Warranty, then CUNO will bear all the reasonable and proper shipping or mailing charges actually incurred in the consumer's return of the Product set forth herein. If the Product proves not to be defective within the terms of this Warranty, then all costs and expenses in connection with the processing of the consumer's claim hereunder shall be borne by the consumer.

RESPONSIBILITY OF THE CONSUMER

The original purchaser-consumer's sole responsibility in the instance of a Warranty claim shall be to notify CUNO of the defect, malfunction, or other manner in which the terms of this Warranty are violated. You may secure performance or obligations hereunder by (in writing):

1. Identifying the Product involved (by model or serial number or other sufficient description that will allow CUNO to determine which Product is defective).
2. Specifying where, when and from whom the Product was purchased.
3. Describing the nature of the defect, malfunction or other violation of this Warranty.
4. Sending such notification to:
CUNO Incorporated, 12628 U.S. 33 North, Churubusco, IN U.S.A.
5. And, making the product available for inspection by CUNO or its authorized representative.

THIS WARRANTY GIVES YOU SPECIFIC LEGAL RIGHTS, AND YOU MAY ALSO HAVE OTHER RIGHTS WHICH MAY VARY FROM STATE TO STATE.

*water softeners only

WATER TREATMENT SYSTEM WARRANTY/RECORD OF PURCHASE CARD

IMPORTANT NOTICE: THIS CARD MUST BE RETURNED WITHIN TEN (10) DAYS OF PURCHASE TO REGISTER YOUR WARRANTY
CUNO Incorporated, 12628 U.S. 33 North, Churubusco, IN U.S.A.

PLEASE PRINT
THANK YOU

DATE OF PURCHASE
Mo. Yr.

Your Name _____
Business Name _____
Address _____
Telephone Number (____) _____
E-mail Address _____

Model # _____

Where Purchased _____

Business Address _____
Street City State & Zip Code

Equipment this system is used on _____

Model # (if known) _____ Manufacturer _____

If the filter is used on more than one machine, please list below.

Equipment Model Manufacturer